

Digital Multimeter

NOTE

This manual documents the Models 8010A and 8012A and their assemblies at the revision levels shown in Appendix 7A. If your instrument contains assemblies with different revision letters, it will be necessary for you to either update or backdate this manual. Refer to the supplemental change/errata sheet for newer assemblies, or to the backdating sheet in Appendix 7A for older assemblies.

8010A 8012A

Digital Multimeter

Instruction Manual

P/N 491944
August 1978
Rev. 1 9/78



Dear Customer:

Congratulations! We at Fluke are proud to present you with the 8010A and 8012A Multimeters. These instruments represent the very latest in integrated circuit and display technology. As a result, the end products are rugged and reliable instruments whose performance and design exhibit the qualities of finely engineered lab instruments. They also provide some unique measurement capabilities in addition to those normally found in an ordinary multimeter.

To fully appreciate and protect your investment, we suggest that you take a few moments to read the manual. As always, Fluke stands behind your instrument with a full one-year warranty and a worldwide service organization. If the need arises, please don't hesitate to call on us.

Thank you for your trust and confidence.

JOHN FLUKE MFG. CO., INC.



static awareness



A Message From
John Fluke Mfg. Co., Inc.

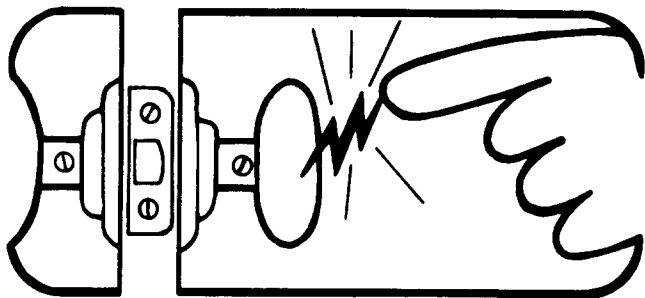

Some semiconductors and custom IC's can be damaged by electrostatic discharge during handling. This notice explains how you can minimize the chances of destroying such devices by:

1. Knowing that there is a problem.
2. Learning the guidelines for handling them.
3. Using the procedures, and packaging and bench techniques that are recommended.

The Static Sensitive (S.S.) devices are identified in the Fluke technical manual parts list with the symbol "⊗".

The following practices should be followed to minimize damage to S.S. devices.

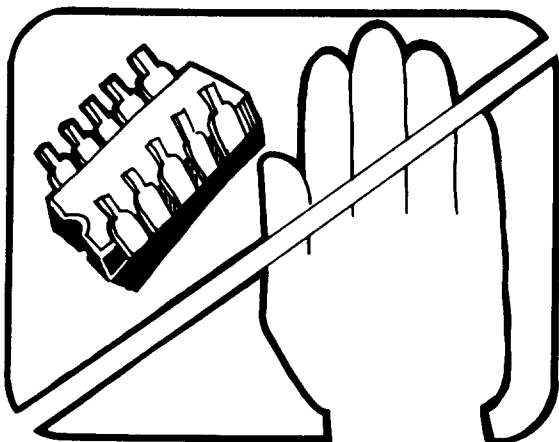

1. MINIMIZE HANDLING

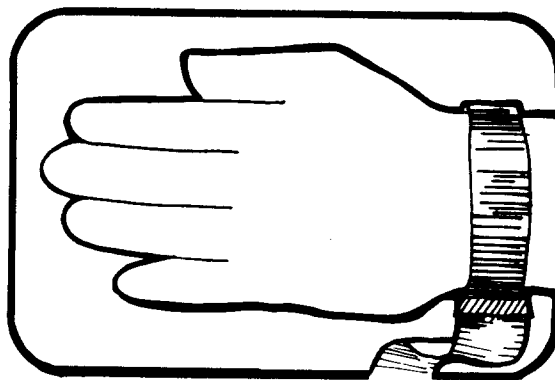

3. DISCHARGE PERSONAL STATIC BEFORE HANDLING DEVICES



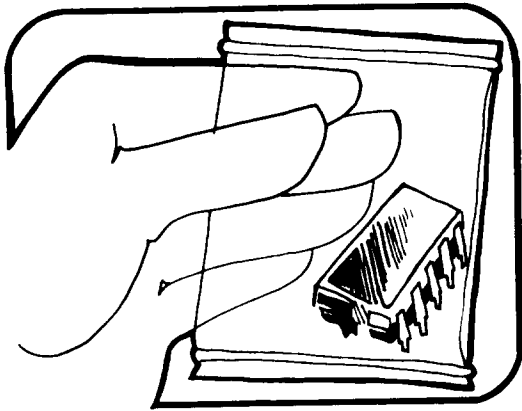

5. USE ANTI-STATIC CONTAINERS FOR HANDLING AND TRANSPORT

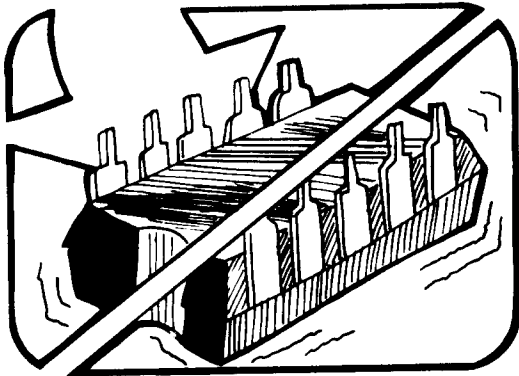

6. DO NOT SLIDE S.S. DEVICES OVER ANY SURFACE

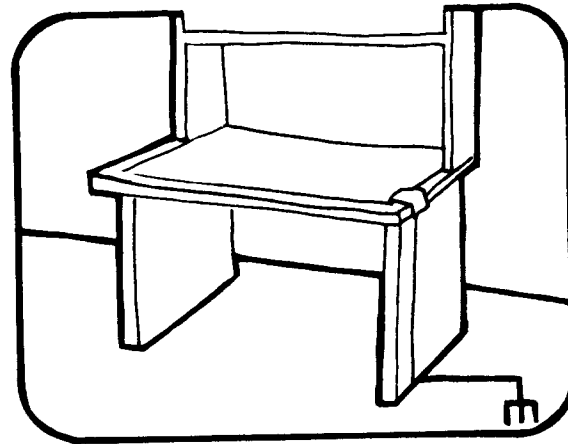
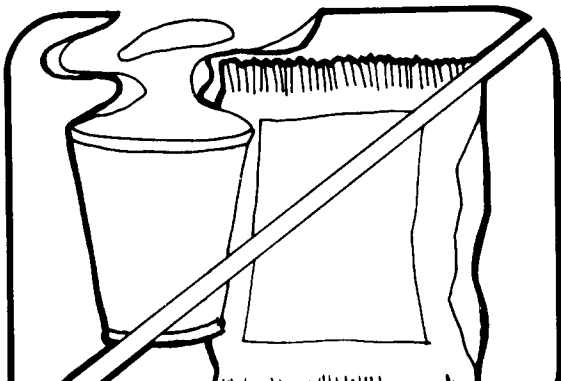

8. HANDLE S.S. DEVICES ONLY AT A STATIC-FREE WORK STATION
9. ONLY ANTI-STATIC TYPE SOLDER-SUCKERS SHOULD BE USED.
10. ONLY GROUNDED TIP SOLDERING IRONS SHOULD BE USED.

Anti-static bags, for storing S.S. devices or pcs with these devices on them, can be ordered from the John Fluke Mfg. Co., Inc.. See section 5 in any Fluke technical manual for ordering instructions. Use the following part numbers when ordering these special bags.

John Fluke
Part No.
453522

Bag Size

6" x 8"

6" x 10"

Table of Contents

SECTION	TITLE	PAGE
1	INTRODUCTION AND SPECIFICATIONS	1-1
1-1	INTRODUCTION	1-1
1-5	UNPACKING YOUR INSTRUMENT	1-1
1-7	GETTING ACQUAINTED	1-2
1-12	USING YOUR METER	1-2
1-14	The LCD	1-2
1-16	Power Switch	1-2
1-18	AC/DC Select	1-2
1-20	Voltage Measurements	1-2
1-25	Current Measurements	1-3
1-29	10A Current Measurements - 8010A Only	1-4
1-31	Resistance Measurements	1-4
1-34	LO RANGE Ω Measurements - 8012A Only	1-4
1-37	Conductance Measurements	1-5
1-39	SPECIFICATIONS	1-5
2	OPERATING INSTRUCTIONS	2-1
2-1	INTRODUCTION	2-1
2-3	OPERATING NOTES	2-1
2-5	Input Power	2-1
2-7	Display Readings	2-1
2-11	Input Connections to Common	2-2
2-13	Input Overload Protection	2-2
2-15	Fuse Replacement	2-3
2-17	Making Voltage Measurements	2-3
2-20	Making Current Measurements	2-3

TABLE OF CONTENTS, *continued*

SECTION	TITLE	PAGE
3-21	Digital Controller	3-4
3-23	Display	3-4
3-25	INPUT SIGNAL CONDITIONERS	3-4
3-27	True RMS Converter	3-4
3-29	Voltage Conditioner	3-4
3-31	Current Conditioner	3-6
3-34	Resistance Conditioner	3-6
3-38	Conductance Conditioner	3-6
3-40	Range Switches	3-6
3-42	MISCELLANEOUS CIRCUITRY	3-6
3-43	Meter Protection Circuits	3-6
3-53	Power Supply	3-7
3-56	Touch and Hold Circuit	3-7
4	MAINTENANCE	4-1
4-1	INTRODUCTION	4-1
4-3	SERVICE INFORMATION	4-1
4-7	GENERAL INFORMATION	4-1
4-8	Access Information	4-1
4-17	Cleaning	4-4
4-19	Special Test Devices	4-4
4-25	PERFORMANCE TESTS	4-4
4-28	Display Test	4-5
4-30	Resistance/Conductance Test	4-5
4-32	LO RANGE Ω Test-8012A Only	4-6
4-34	DC Voltage Test	4-6
4-36	RMS Converter Offset Test	4-6
4-38	AC Voltage Test	4-6
4-40	DC Current Test	4-7
4-42	AC Current Test	4-7
4-44	10A Current Test - 8010A Only	4-7
4-46	CALIBRATION PROCEDURE	4-8
4-48	Power Supply Check	4-8
4-50	DC Calibration Adjustment	4-8
4-52	RMS Converter Offset Adjustment	4-8
4-54	AC Calibration Adjustment	4-9
4-56	LO RANGE Ω Calibration Adjustment	4-9
4-58	TROUBLESHOOTING	4-9
5	LIST OF REPLACEABLE PARTS	5-1
5-1	INTRODUCTION	5-2
5-4	HOW TO OBTAIN PARTS	5-2
6	OPTION AND ACCESSORIES	6-1
7	GENERAL INFORMATION	7-1
7A	MANUAL CHANGE INFORMATION	7A-1
8	SCHEMATIC DIAGRAMS	8-1

List of Tables

TABLE	TITLE	PAGE
1-1	Specifications	1-5
2-1	Overload Limits	2-2
4-1	List of Recommended Test Equipment	4-2
4-2	Decimal Point Location	4-5
4-3	Resistance/Conductance Test	4-6
4-4	DC Voltage Test	4-6
4-5	AC Voltage Test	4-7
4-6	DC mA Test	4-7
4-7	Power Supply Voltages	4-8
4-8	Troubleshooting Guide	4-10
4-9	Test Points	4-11
600-1	Rack Mounting Kits	600-2

List of Illustrations

FIGURE	TITLE	PAGE
	Frontispiece	vi
1-1	LCD	1-2
1-2	Voltage Measurement	1-3
1-3	mA Measurement	1-4
1-4	10A Current Measurement - 8010A Only	1-4
1-5	Resistance Measurement	1-4
1-6	LO RANGE Ω Measurement - 8012A Only	1-5
1-7	Conductance Measurement	1-5
2-1	Voltage Conversion	2-4
2-2	Circuit Loading Error Calculation	2-5
2-3	RMS Values	2-5
2-4	Calculating Burden Voltage Error	2-6
2-5	Conductance-to-Resistance Conversion	2-8
2-6	Crest Factor	2-9
2-7	Components of a Rectangular Waveform	2-10
2-8	Example	2-11
2-9	Transistor Beta Tester	2-12
3-1	Basic Block Diagram	3-2
3-2	A/D Converter Simplified Schematic and Timing Diagram	3-3
3-3	Input Signal Conditioners	3-5
4-1	Removing the mA Input Line	4-3
4-2	19 Ω and 1.9 Ω Test Sets	4-4
600-1	Model C80 Carrying Case	600-1
600-2	Model C86 Carrying Case	600-2
600-3	Rack Mounting Kits, Offset and Center Mounting	600-3
600-4	Rack Mounting Kits, Side-by-Side	600-4
600-5	Probe Accessories	600-4

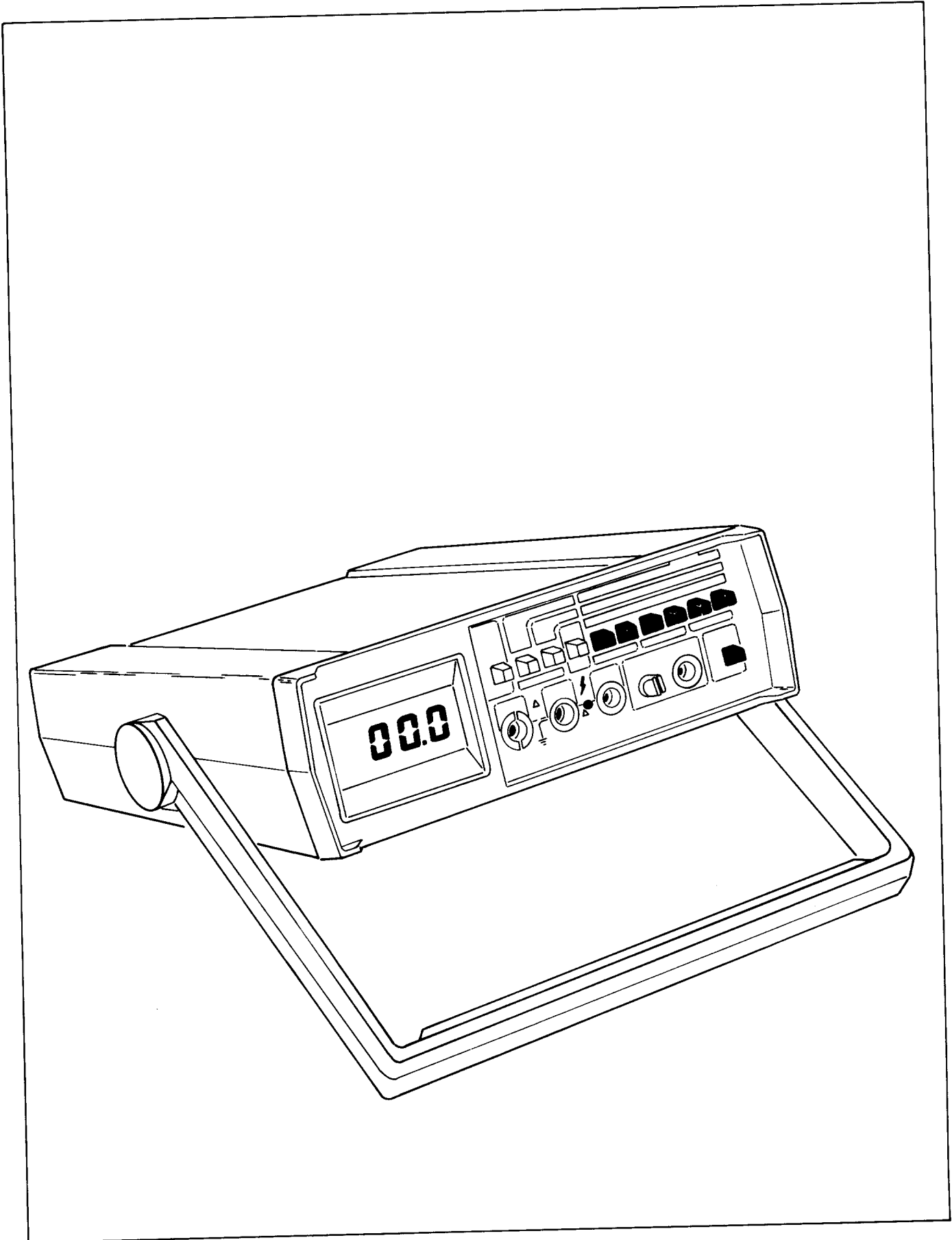

8010A/8012A Digital Multimeter

Section 1

Introduction & Specifications

1-1. INTRODUCTION

1-2. The Fluke Models 8010A and 8012A are portable, bench-type, digital multimeters with 3 1/2 digit liquid crystal display (LCD). Both offer as standard measurement functions the five basic DMM functions (AC/DC voltage, AC/DC current, and resistance) and a new measurement function-conductance. In addition, if you bought an 8010A, you have a high current measurement function of up to 10A. If you bought an 8012A, you have two ranges of low resistance measurements - 20 Ω and 2 Ω .

1-3. Your meter also has advantages that don't show on the outside. Some of these are:

- ▶ True RMS measurement of AC signals - the only accurate way to directly measure ac signals other than noise-free pure sine waves.

- ▶ 3 1/2 digit liquid crystal display - a high contrast display that can be read easily from across the room. No more worries about bent needles, parallax, etc.

- ▶ Each range has:

Full auto-polarity operation.

Overrange indication.

Effective protection for overloads and transients.

Dual slope integration measurement technique to insure fast, accurate, noise-free measurements.

- ▶ The conductance ranges allow accurate, noise-free measurement up to 10,000 M Ω .

- ▶ Long term calibration stability - 1 year. Easy calibration - few adjustments.

- ▶ A full line of accessories that extend the range and scope of your instrument:

Touch and Hold Probe allows voltage, resistance and conductance readings to be held in the display.

High Current Probe allows your meter to measure from 2A to 600A.

High Voltage Probe allows your meter to measure from 1 kV to 40 kV dc or peak ac, 28 kV rms ac.

High Frequency Probe allows your meter to measure signals from 0.25V to 30V rms ac over a frequency range of 100 kHz to 100 MHz.

Temperature Probe allows your meter to measure temperature of -50°C to +150°C or -58°F to +302°F.

NOTE

For more information on these accessories, refer to the material presented in Section 6.

1-4. The 8010A and 8012A are the same instrument with one exception each - the 8010A has the 10 amp function and the 8012A has the LO RANGE Ω function. If a portion of the text deals with just the 8010A or just the 8012A, then we'll say so. Otherwise, the text applies to both instruments.

1-5. UNPACKING YOUR INSTRUMENT

1-6. The shipping container should contain this manual, your multimeter, two test leads (one red and one black), and any accessories you have ordered. Turn the instrument upside-down, the large decal on the bottom of the multimeter has been marked with the line voltage and line frequency of the input power of your operating environment. The marked values should agree with your order. If you ordered your instrument equipped with a selectable line frequency, the decal will be marked with the line frequency selected at the factory. If anything is wrong with your shipment or if the instrument was damaged during shipment, contact your nearest John Fluke Service Center immediately. There is a list of these service centers in Section 7. If reshipment is required, please use the original shipping container.

1-7. GETTING ACQUAINTED

1-8. Let's take a brief look at your instrument before we discuss exactly how to operate it.

1-9. The meter is light (2 pounds and 6 ounces for the standard model) with a low profile that hugs the work bench. The light grey case goes with any decor and is made of rugged, high impact plastic. The handle can be rotated to eight positions to function as a handle for carrying the instrument or as a stand to tilt the front panel up for convenient operation. The handle can be rotated out of the way. To change the handle position, pull out on the round hubs where the handle joins the meter then rotate the handle to the desired position.

1-10. On the rear of the meter are a phillips screw and a power cord receptacle. The phillips screw holds the outer cover in place.

1-11. The LCD (liquid crystal display) covers the left part of the front panel. The right hand portion of the front panel contains two horizontal rows of controls and connectors. The top row consists of ten pushbuttons - the four switches on the left determine the measurement function of your multimeter and the other six switches determine the range of measurement. The bottom row consists of controls and the input terminals.

1-12. USING YOUR METER

1-13. This portion of the text will discuss the operation and characteristics of your meter in detail for each measurement function. Exercises are included to familiarize you with the instrument controls and to insure that your instrument is functional.

1-14. The LCD

1-15. The LCD is a 3 1/2 digit display. As shown in Figure 1-1, this display is made up of four digits. The three digits on the right can each register a count of 0 to 9. Together they register from 000 to 999. The digit on the left can register the minus sign and a 1 overflow from the three digits on the right. This is the 1/2 digit. Together the four digits can count from -1999 to +1999. For convenience of discussion, we will round the 1999 to 2000.

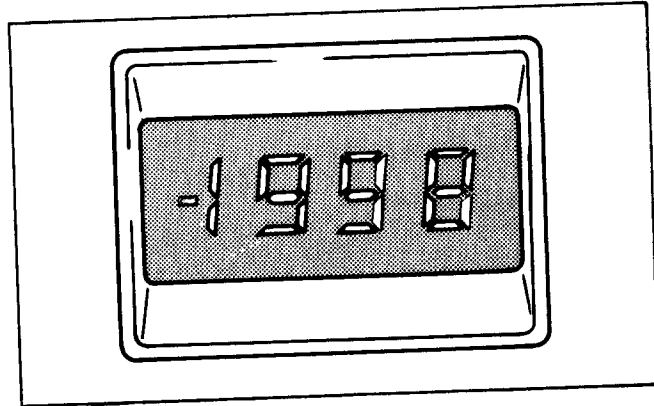

Figure 1-1. LCD

1-16. Power Switch

1-17. The POWER switch is the green switch in the lower right corner of the front panel. As the decal indicates, the pushbutton is a two position switch, ON and OFF. To change from one condition to the other, push the switch (never pull). If the button is out, or in the OFF position, push it. The control will lock in the ON position. Push the control again and the button will pop out to the OFF position.

1-18. AC/DC Select

1-19. The position of the pushbutton at the left end of the upper row of controls determines whether your instrument will be set up to read dc or ac signals. Operation of this control is exactly like the POWER control. As the decal shows, if the pushbutton is in, ac-coupled measurement is selected. If the pushbutton is out, dc measurement is selected. This control will only affect your instrument when either a voltage or current function is selected.

1-20. Voltage Measurements

1-21. The controls and terminals used for making voltage measurements are highlighted in Figure 1-2. Starting at the top, left is the AC/DC switch. Next is the V pushbutton. This pushbutton is interlocked with the

other two white measurement function select switches, mA/A and k Ω /S. That is, if the V pushbutton is locked at the in position and either of the other two pushbuttons are pressed, the V pushbutton will pop to the out position. The pushbutton must be locked at the in position to determine measurement function. Push the V switch in.

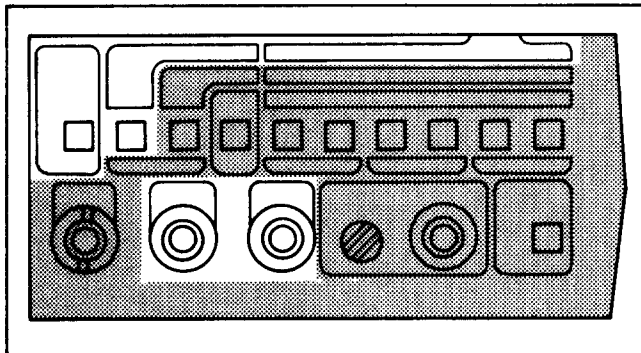

Figure 1-2. Voltage Measurement

1-22. The light green decal around the V control extends up and to the right. The five ranges of the voltage function are labeled in this green band over their respective range selection switches. These switches are all interlocked in the same manner as the three measurement function switches. Select the 2V range.

1-23. The two input terminals highlighted in the bottom row are banana jack connectors. The one on the left is labeled COMMON and has a black decal. This terminal is common to all measurement functions and the black test lead should always be connected here. A curved line with a note goes to the left and down from the COMMON input terminal. This note is a reminder to not measure signals where the COMMON lead will be more than 500V above ground potential. The other input terminal is labeled V/k Ω /S on a red decal. The red test lead is connected here for voltage, standard resistance, and conductance measurements. Between the two terminals is a hole and a thin connecting line with a subtended note. The note reminds the operator that signals exceeding 750V ac rms or 1000V dc should not be measured between the terminals. The hole is a key guide for the optional Touch and Hold Probe. Connect the test leads to the terminals.

1-24. Let's perform the following procedure.

1. Set the AC/DC switch to the DC position.
2. With the POWER switch in the OFF position, connect the power cord to the instrument and a line power outlet rated at the operating voltage and frequency of your instrument.

3. Press the POWER switch to ON. The LCD should flash a random number. Then count down rapidly to a reading of .000 (because the 2V range is selected).

4. Touch the sampling end of the red test lead to the far left terminal labeled mA. A firm contact must be made or the display may be in error. The LCD should display approximately 0.6V to 0.8V. This is the signal voltage for the optional Touch and Hold Probe. It is not an accurate voltage level and varies from instrument to instrument. This voltage is not present when a current measurement function is selected. For more information on the Touch and Hold Probe, refer to Section 6.

5. Place the AC/DC switch in the AC position. The LCD should count down to a reading that is typically .000 to .002 - the dc signal has been eliminated.

6. Remove the red test lead from the mA input terminal.

7. Select the 750V ac rms range.

WARNING

THE LOCAL LINE VOLTAGE IS MEASURED IN THE FOLLOWING STEP. BE CAREFUL NOT TO TOUCH THE PROBE TIPS WITH YOUR FINGERS OR TO ALLOW THE PROBE TIPS TO TOUCH EACH OTHER.

8. Insert the sampling ends of the test leads into the slots of a line power outlet. The LCD should display the local line voltage. This voltage probably will not be at the rated level but should be close.

9. Press the AC/DC switch to select DC measurements. This will reject the ac portion of the signal. There may be some dc voltage displayed due to non-linear loads such as SCR light dimmers.

10. Remove the test leads from the line power outlet.

1-25. Current Measurements

1-26. The controls and terminals used for making current measurements are highlighted in Figure 1-3. The AC/DC switch and the mA switch determine the measurement function. On the 8010A, the current switch is labeled mA/A because the same switch selects the high current measurement range also.

1-5. UNPACKING YOUR INSTRUMENT

1-6. The shipping container should contain this manual, your multimeter, two test leads (one red and one black), and any accessories you have ordered. Turn the instrument upside-down, the large decal on the bottom of the multimeter has been marked with the line voltage and line frequency of the input power of your operating environment. The marked values should agree with your order. If you ordered your instrument equipped with a selectable line frequency, the decal will be marked with the line frequency selected at the factory. If anything is wrong with your shipment or if the instrument was damaged during shipment, contact your nearest John Fluke Service Center immediately. There is a list of these service centers in Section 7. If reshipment is required, please use the original shipping container.

1-7. GETTING ACQUAINTED

1-8. Let's take a brief look at your instrument before we discuss exactly how to operate it.

1-9. The meter is light (2 pounds and 6 ounces for the standard model) with a low profile that hugs the work bench. The light grey case goes with any decor and is made of rugged, high impact plastic. The handle can be rotated to eight positions to function as a handle for carrying the instrument or as a stand to tilt the front panel up for convenient operation. The handle can be rotated out of the way. To change the handle position, pull out on the round hubs where the handle joins the meter then rotate the handle to the desired position.

1-10. On the rear of the meter are a phillips screw and a power cord receptacle. The phillips screw holds the outer cover in place.

1-11. The LCD (liquid crystal display) covers the left part of the front panel. The right hand portion of the front panel contains two horizontal rows of controls and connectors. The top row of consists of ten pushbuttons - the four switches on the left determine the measurement function of your multimeter and the other six switches determine the range of measurement. The bottom row consists of controls and the input terminals.

1-12. USING YOUR METER

1-13. This portion of the text will discuss the operation and characteristics of your meter in detail for each measurement function. Exercises are included to familiarize you with the instrument controls and to insure that your instrument is functional.

1-14. The LCD

1-15. The LDC is a 3 1/2 digit display. As shown in Figure 1-1, this display is made up of four digits. The three digits on the right can each register a count of 0 to 9. Together they register from 000 to 999. The digit on the left can register the minus sign and a 1 overflow from the three digits on the right. This is the 1/2 digit. Together the four digits can count from -1999 to +1999. For convenience of discussion, we will round the 1999 to 2000.

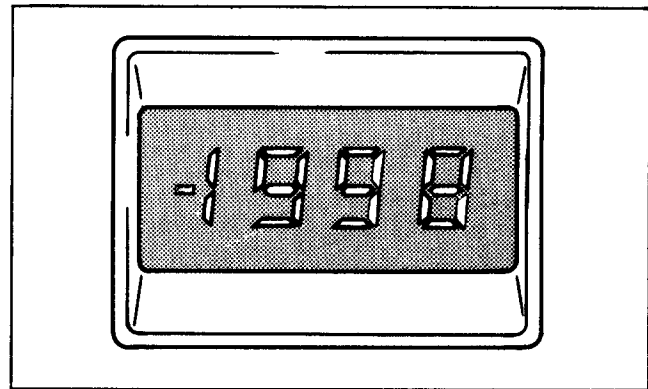

Figure 1-1. LCD

1-16. Power Switch

1-17. The POWER switch is the green switch in the lower right corner of the front panel. As the decal indicates, the pushbutton is a two position switch, ON and OFF. To change from one condition to the other, push the switch (never pull). If the button is out, or in the OFF position, push it. The control will lock in the ON position. Push the control again and the button will pop out to the OFF position.

1-18. AC/DC Select

1-19. The position of the pushbutton at the left end of the upper row of controls determines whether your instrument will be set up to read dc or ac signals. Operation of this control is exactly like the POWER control. As the decal shows, if the pushbutton is in, ac-coupled measurement is selected. If the pushbutton is out, dc measurement is selected. This control will only affect your instrument when either a voltage or current function is selected.

1-20. Voltage Measurements

1-21. The controls and terminals used for making voltage measurements are highlighted in Figure 1-2. Starting at the top, left is the AC/DC switch. Next is the V pushbutton. This pushbutton is interlocked with the

other two white measurement function select switches, mA/A and k Ω /S. That is, if the V pushbutton is locked at the in position and either of the other two pushbuttons are pressed, the V pushbutton will pop to the out position. The pushbutton must be locked at the in position to determine measurement function. Push the V switch in.

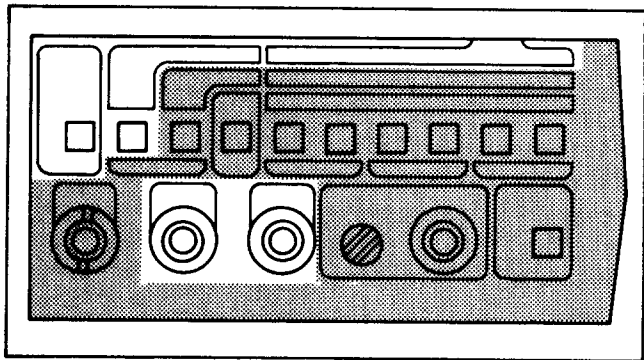

Figure 1-2. Voltage Measurement

1-22. The light green decal around the V control extends up and to the right. The five ranges of the voltage function are labeled in this green band over their respective range selection switches. These switches are all interlocked in the same manner as the three measurement function switches. Select the 2V range.

1-23. The two input terminals highlighted in the bottom row are banana jack connectors. The one on the left is labeled COMMON and has a black decal. This terminal is common to all measurement functions and the black test lead should always be connected here. A curved line with a note goes to the left and down from the COMMON input terminal. This note is a reminder to not measure signals where the COMMON lead will be more than 500V above ground potential. The other input terminal is labeled V/k Ω /S on a red decal. The red test lead is connected here for voltage, standard resistance, and conductance measurements. Between the two terminals is a hole and a thin connecting line with a subtended note. The note reminds the operator that signals exceeding 750V ac rms or 1000V dc should not be measured between the terminals. The hole is a key guide for the optional Touch and Hold Probe. Connect the test leads to the terminals.

1-24. Let's perform the following procedure.

1. Set the AC/DC switch to the DC position.
2. With the POWER switch in the OFF position, connect the power cord to the instrument and a line power outlet rated at the operating voltage and frequency of your instrument.

3. Press the POWER switch to ON. The LCD should flash a random number. Then count down rapidly to a reading of .000 (because the 2V range is selected).

4. Touch the sampling end of the red test lead to the far left terminal labeled mA. A firm contact must be made or the display may be in error. The LCD should display approximately 0.6V to 0.8V. This is the signal voltage for the optional Touch and Hold Probe. It is not an accurate voltage level and varies from instrument to instrument. This voltage is not present when a current measurement function is selected. For more information on the Touch and Hold Probe, refer to Section 6.

5. Place the AC/DC switch in the AC position. The LCD should count down to a reading that is typically .000 to .002 - the dc signal has been eliminated.

6. Remove the red test lead from the mA input terminal.

7. Select the 750V ac rms range.

WARNING

THE LOCAL LINE VOLTAGE IS MEASURED IN THE FOLLOWING STEP. BE CAREFUL NOT TO TOUCH THE PROBE TIPS WITH YOUR FINGERS OR TO ALLOW THE PROBE TIPS TO TOUCH EACH OTHER.

8. Insert the sampling ends of the test leads into the slots of a line power outlet. The LCD should display the local line voltage. This voltage probably will not be at the rated level but should be close.

9. Press the AC/DC switch to select DC measurements. This will reject the ac portion of the signal. There may be some dc voltage displayed due to non-linear loads such as SCR light dimmers.

10. Remove the test leads from the line power outlet.

1-25. Current Measurements

1-26. The controls and terminals used for making current measurements are highlighted in Figure 1-3. The AC/DC switch and the mA switch determine the measurement function. On the 8010A, the current switch is labeled mA/A because the same switch selects the high current measurement range also.

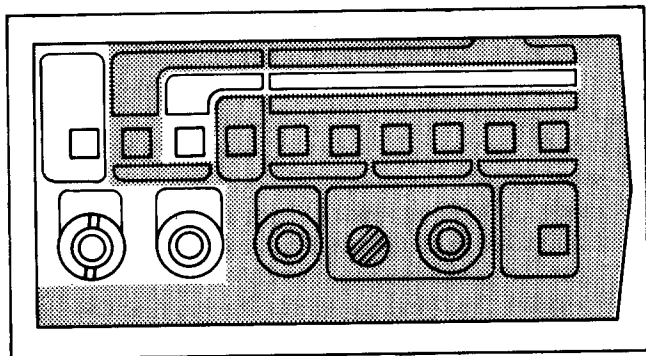

Figure 1-3. mA Measurement

1-27. The pink decal around the mA control extends up and to the right. The ranges of current measurement are labeled in this pink band above their respective range selection switches.

1-28. The two input terminals are the COMMON terminal and the mA terminal. There is a line between them with a note to remind the operator that current measurements over 2A should not be read between these terminals. The mA terminal is also the end of a protective fuse holder. The collar is slotted to facilitate fuse replacement. There is a curved arrow with a 2A fuse note to the left of the mA terminal to indicate how to remove the 2A fuse. For additional information on fuse replacement, refer to Section 2.

1-29. 10A Current Measurement - 8010A Only

1-30. The controls and terminals used for the 10A current measurement function are highlighted in Figure 1-4. The AC/DC and mA switches and the last range switch on the right select the 10A current measurement function. The COMMON and 10A terminals are used for signal input. The 10A input terminal is labeled to remind the operator that the maximum current measured between these two terminals is 10A and that the function is not fuse protected.

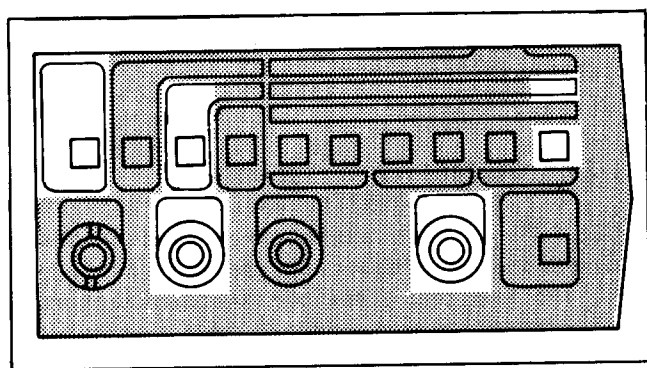

Figure 1-4. 10A Current Measurement - 8010A Only

1-31. Resistance Measurements

1-32. The controls and terminals used for making resistance measurements are highlighted in Figure 1-5. The measurement function is selected by the kΩ/S switch. The tan decal extends up and to the right with the six ranges of resistance in the standard resistance function labeled in this tan band over their respective range switches. The COMMON and V/kΩ/S terminals are used for signal input.

1-33. Let's use the following procedure to exercise the resistance function and see how the range switches affect the position of the decimal point on the display.

1. Select the resistance function, 2000 kΩ range.
2. The LCD should display an overrange indication, a 1 with the three right hand digits blank.
3. Connect the test leads to the input terminals, black lead to COMMON and red lead to V/kΩ/S.
4. Make a firm connection between the sampling ends of the test leads. The LCD should count down to a reading of 000.
5. Maintaining a firm contact between the sampling ends of the test leads, sequentially select the ranges starting with the 200Ω range switch. The decimal point for each should be as follows:

200Ω	00.0*	200 kΩ	00.0
2 kΩ	.000	2000 kΩ	000
20 kΩ	0.00	20 mΩ	0.00

* Display may display .1 or .2Ω of lead resistance.

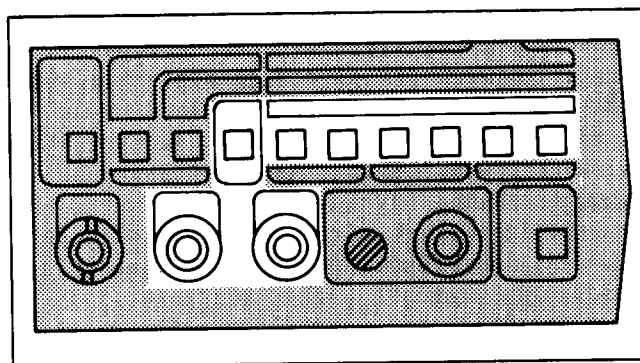

Figure 1-5. Resistance Measurement

1-34. Lo Range Ω Measurements - 8012A Only

1-35. The controls and terminals used for making low resistance measurements with the 8012A are highlighted in Figure 1-6. The LO RANGE Ω measurement function

is selected by simultaneously pressing in the V and mA function select switches. This is indicated by the grey decal below the two switches. The two terminals used are the COMMON and LO RANGE Ω input terminal. The ZERO control located next to the LO RANGE Ω terminal is used to compensate for test lead resistance. Two of the range switches are used to select either the 2Ω or 20Ω range. These range switches are indicated by the respective labels on the grey decal around the ZERO control and the LO RANGE Ω terminal. These switches also select the 2 and 20 ranges for the other instrument functions.

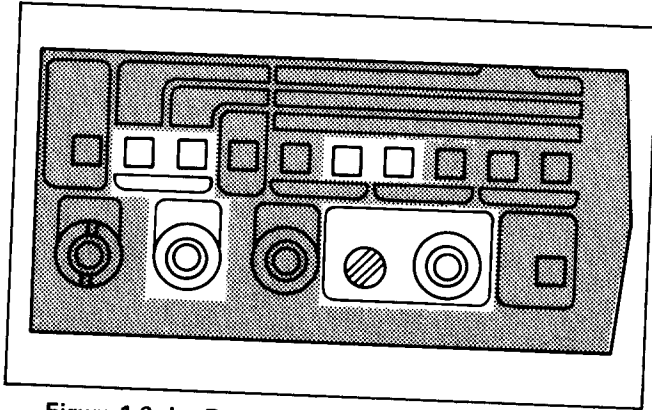

Figure 1-6. Lo Range Ω Measurement - 8012A Only

1-36. To use the LO RANGE Ω function, select the function and connect the test leads to the input terminals. Select the 2Ω range. Make a firm contact between the sampling ends of the test leads. Adjust the ZERO control until the display reads all zeros. You have now compensated for the resistance of your test leads. You can now use either range. If you want to measure a low

resistance device, remove the 2A fuse located behind the mA terminal. The fuse reads approximately $50\text{ m}\Omega$. For instructions on removing the fuse, refer to the appropriate information in Section 2.

1-37. Conductance Measurements

1-38. The controls and terminals for making conductance measurements are highlighted in Figure 1-7. With the exception of the selection of range, the controls and connections are exactly the same as for resistance measurements. There are three ranges of conductance. Each range is selected by simultaneously pushing in two range switches. The pairs of range switches required are indicated by the three grey decals below the range switches.

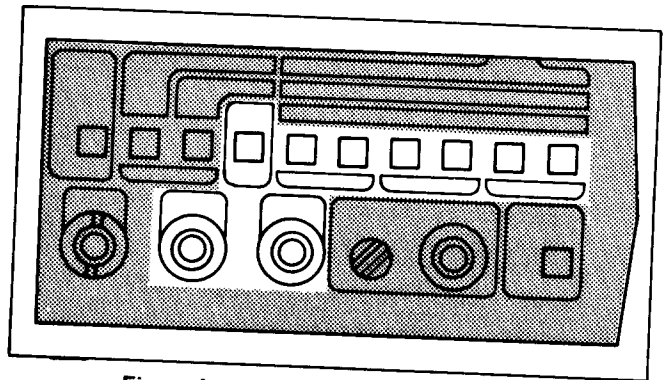

Figure 1-7. Conductance measurement

1-39. SPECIFICATIONS

1-40. Detailed specifications for both the 8010A and the 8012A are given in Table 1-1.

Table 1-1. 8010A/8012A Specifications

ELECTRICAL:		The electrical specifications given assume an operating temperature of 18°C to 28°C , humidity up to 90%, and a 1-year calibration cycle.
FUNCTIONS:		
DC VOLTS:		
RANGE	RESOLUTION	ACCURACY for 1-Year $\pm(0.1\% \text{ of reading} + 1 \text{ digit})$
$\pm 200\text{ mV}$	$100\ \mu\text{V}$	
$\pm 2\text{V}$	1 mV	
$\pm 20\text{V}$	10 mV	
$\pm 200\text{V}$	100 mV	
$\pm 1000\text{V}$	1V	
INPUT IMPEDANCE:		$10\text{ M}\Omega$, all ranges.
NORMAL MODE REJECTION RATIO:		$> 60\text{ dB}$ at 60 Hz (at 50 Hz on 50 Hz Option).

Table 1-1. 8010A/8012A Specifications (cont)

COMMON MODE REJECTION RATIO: > 120 dB at dc, 50 Hz and 60 Hz.
(1 k Ω unbalance)

OVERVOLTAGE PROTECTION: 1000V dc or peak ac on all ranges.

RESPONSE TIME: 1 second.

AC VOLTS (TRUE RMS RESPONDING):

RANGE	RESOLUTION	ACCURACY for 1-Year			
		45 Hz		10 kHz	20 kHz
		to 1 kHz	to 10 kHz	to 20 kHz	to 50 kHz
200 mV	100 μ V	$\pm(0.5\%$ of reading + 2 digits)		$\pm(1.0\%$ of reading + 2 digits)	$\pm(5\%$ of reading + 3 digits)
2V	1 mV				
20V	10 mV				
200V	0.1V				
750V	1V	$\pm(0.5\%$ of reading + 2 digits)			

VOLT-Hz PRODUCT: 10^7 max (200V max @ 50 kHz).

EXTENDED FREQUENCY RESPONSE: Typically ± 3 dB at 200 kHz.

COMMON MODE NOISE REJECTION RATIO (1 k Ω unbalance): > 60 dB at 50 Hz and 60 Hz.

CREST FACTOR RANGE: 1.0 to 3.0.

INPUT IMPEDANCE: 10 M Ω in parallel with < 100 pF.

OVERLOAD PROTECTION: 750V rms or 1000V peak continuous not to exceed the volt-hertz product of 10^7 (except 10 seconds maximum on 200 mV, 2V ranges).

RESPONSE TIME: 2 seconds maximum within a range.

DC CURRENT:

RANGE	RESOLUTION	ACCURACY for 1-Year	BURDEN VOLTAGE
20 μ A	0.1 μ A	$\pm(0.3\%$ of reading + 1 digit)	0.3V max.
2 mA	1 μ A		
20 mA	10 μ A		
200 mA	100 μ A		
2000 mA	1 mA		0.9V max.

OVERLOAD PROTECTION: 2A/250V fuse in series with 3A/600V fuse (for high energy sources).

Table 1-1. 8010A/8012A Specifications (cont)

AC CURRENT (TRUE RMS RESPONDING):

RANGE	RESOLUTION	ACCURACY: from 5% of range to full-scale, 1-Year			BURDEN VOLTAGE
		45 Hz to 2 kHz	45 Hz to 10 kHz	10 kHz to 20 kHz	
200 μ A	0.1 μ A	$\pm(1\%$ of reading +2 digits)		$\pm(2\%$ of reading +2 digits)	0.3V rms max.
2 mA	1 μ A				
20 mA	10 μ A				
200 mA	100 μ A				
2000 mA	1 mA	$\pm(1\%$ of reading +2 digits)			0.9V rms max.

OVERLOAD PROTECTION:

2A/250V fuse in series with 3A/600V fuse (for high energy sources).

CREST FACTOR RANGE:

1.0 to 3.0.

HIGH CURRENT-8010A ONLY:

RANGE	RESOLUTION	ACCURACY: for 1-Year	BURDEN VOLTAGE
10A dc	10 mA	$\pm(0.5\%$ of reading + 1 digit)	0.5V max.
10A Trms ac	10 mA	45 Hz to 2 kHz $\pm(1\%$ of reading + 2 digits)	0.5V rms max.

OVERLOAD:

12A max unfused.

RESISTANCE:

RANGE	RESOLUTION	ACCURACY: for 1-Year	FULL-SCALE VOLTAGE	MAXIMUM TEST CURRENT
200 Ω	0.1 Ω	$\pm(0.2\%$ of reading +1 digit)	0.25V	1.3 mA
2 k Ω \rightarrow	1 Ω		1.0V	1.3 mA
20 k Ω	10 Ω		< 0.25V	10 μ A
200 k Ω \rightarrow	100 Ω		1.0V	35 μ A
2000 k Ω	1 k Ω	$\pm(0.5\%$ of reading +1 digit)	< 0.25V	0.10 μ A
20 M Ω \rightarrow	10 k Ω		1.5V	0.35 μ A

OVERLOAD PROTECTION:

300V dc/ac rms on all ranges.

OPEN CIRCUIT VOLTAGE:

Less than 3.5V on all ranges.

RESPONSE TIME:1 second, all ranges except 2000 k Ω and 20 M Ω ranges - 4 seconds these two ranges.**DIODE TEST:**

These three ranges have enough voltage to turn on silicon junctions to check for proper forward-to-back resistance. The 2 k Ω range is preferred and is marked with a larger diode symbol on the front panel of the instrument. The three non-diode test ranges will not turn on silicon junctions so in-circuit resistance measurements can be made with these three ranges.

Table 1-1. 8010A/8012A Specifications (cont)

LOW RESISTANCE-8012A ONLY:

RANGE	RESOLUTION	ACCURACY: for 1-Year	FULL-SCALE VOLTAGE	MAXIMUM TEST CURRENT
2 Ω (LO Ohms)	1 m Ω	$\pm(1\%$ of reading +2 digits)	0.02V	10 mA
20 Ω (LO Ohms)	10 m Ω	$\pm(0.5\%$ of reading +2 digits)	0.2V	10 mA

OVERLOAD PROTECTION:

300V dc/ac rms on all ranges.

RESPONSE TIME:

1 second maximum.

OPEN CIRCUIT VOLTAGE:

16V maximum on both ranges.

CONDUCTANCE:

RANGE	RESOLUTION	ACCURACY: for 1-Year	OPEN CIRCUIT VOLTAGE	MAXIMUM TEST CURRENT
2 mS	1 μ S	$\pm(0.2\%$ of reading + 1 digit)	3.5V	1.3 mA
20 μ S	10 nS		1V	10 μ A
200 nS	.1 nS	$\pm(1\%$ of reading +10 digits)	1V	0.10 μ A

OVERLOAD PROTECTION:

300V dc/ac rms on all ranges.

CONDUCTANCE UNITS:

We use the international unit of conductance, the Siemen = $S = 1/\Omega$. Another unit of conductance is the mho.

ENVIRONMENTAL:**TEMPERATURE COEFFICIENT:**

0.1 times the applicable accuracy specification per $^{\circ}$ C for 0° C to 18° C and 28° C to 50° C (32° F to 64.4° F and 50.4° F to 122° F).

OPERATING TEMPERATURE: 0° C to 50° C (32° F to 122° F).**STORAGE TEMPERATURE:**

(without batteries): -40° C to $+70^{\circ}$ C (-40° F to $+158^{\circ}$ F).
(with batteries): -40° C to $+50^{\circ}$ C (-40° F to $+122^{\circ}$ F).

RELATIVE HUMIDITY:

0 to 80%, 0° C to 35° C ($32-95^{\circ}$ F) on 2000 k Ω , 20 M Ω and 200 nS ranges.
0 to 90%, 0° C to 35° C ($32-95^{\circ}$ F) on all other ranges.
0 to 70%, 35° C to 50° C ($95-122^{\circ}$ F).

GENERAL:**MAXIMUM COMMON MODE VOLTAGE:**

500V dc/ac rms.

POWER REQUIREMENTS:

90-132V, 60 Hz.

SIZE:22 cm X 6 cm X 25 cm ($8\frac{1}{2}$ " X $2\frac{1}{2}$ " X 10").**WEIGHT:**

1.08 kg (2 lb., 6 oz.).

Section 2

Operating Instructions

2-1. INTRODUCTION

2-2. To use your Fluke multimeter fully, there are some additional factors to be considered. This section of the manual gives that information in the operating notes. Also included are some applications you may find useful. For example, a simple device plugged into your instrument will provide direct reading dc-current gain (Beta) measurements for both NPN and PNP transistors.

2-3. OPERATING NOTES

2-4. The operating notes contain information about measurement considerations, peculiarities of your instrument and some simple maintenance procedures. Every person using your instrument should be familiar with these operating notes.

2-5. Input Power

2-6. The Models 8010A and 8012A both are available in three input power versions. The three standard power environments are 115 VAC, 60 Hz; 100 VAC, 50 Hz or 60 Hz selectable; and 230 VAC, 50 Hz. In addition, there is a battery pack option available that will operate off battery power or 90-264 VAC, 50 Hz or 60 Hz. For more information about the battery version, see the material in Section 6 about the -01 Option.

2-7. Display Readings

NOTE

The liquid crystal display used in your instrument is rugged and reliable. With proper care, it will give you years of satisfactory service. The chemicals that make this advanced type of display possible require

certain practices. To extend the life of the display and to make sure that the display will be ready to operate at a moment's notice, observe the following practices:

1. Protect the display from extended exposure to bright sunlight.

2. Keep the instrument out of high temperature and high humidity environments such as the dashboard of a car on a hot, sunny day.

3. Keep the instrument out of low temperature environments. Operation or storage at temperature below -15°C (5°F) may result in the display being sluggish until the instrument is returned to normal operating temperature.

2-8. The display on your meter will provide continuous readings during normal operation and indicate an overrange (overload) condition. The overrange indication is a 1 followed by three blank digits. (A decimal point may be present, depending upon the range selected.) This overrange indication doesn't necessarily mean that the input will damage your instrument. For example, when measuring resistance the overrange indication is displayed to indicate an open input condition.

2-9. During normal operation, the display will be between zero and 9999. The position of the decimal point is determined by the range selected and is not affected by the measurement function selected. An indication of polarity is valid for voltage and current measurements. The minus sign indicates that the input voltage or current is negative with respect to the COMMON input terminal. Voltage or current inputs that are positive with respect to COMMON are indicated by the absence of a minus sign.

2-10. There are two other conditions that will cause the negative sign to be displayed. Neither indicates a valid display. When your instrument comes out of an overrange condition, the minus sign may flash momentarily. This is most likely seen when reading resistance. When the test leads are not connected to anything, the meter will indicate an open condition (overrange indication). When the test leads are connected to an in range resistance, the meter will come out of the overrange condition and the minus sign may flash. If you are reading resistance and the minus sign remains on, there is still energy in the circuit being measured. The circuitry may still have power applied, a capacitor may still be charged, etc. You will only get this indication of an energized circuit if the power in the circuit is negative with respect to the COMMON input terminal. If the power in the circuit is positive with respect to the COMMON input terminal, an erroneous resistance will be displayed. If there is any doubt about whether there is energy remaining in the circuit you are reading, read the resistance, then reverse the test lead positions. If a minus sign is displayed in either case, the remaining energy must be removed from the circuit before correct resistance readings can be made.

2-11. Input Connections to Common

WARNING

TO AVOID ELECTRICAL SHOCK AND/OR INSTRUMENT DAMAGE DO NOT CONNECT THE COMMON INPUT TERMINAL TO ANY SOURCE OF MORE THAN 500 VOLTS DC OR PEAK AC ABOVE EARTH GROUND.

2-12. Your instrument can be operated with the COMMON input terminal at a potential above earth ground of up to 500V dc or 500V peak ac. If this limit is exceeded, instrument damage may occur. This may present a safety hazard to the operator - you.

2-13. Input Overload Protection

CAUTION

Exceeding the maximum input overload limits can damage your instrument.

2-14. There are protection circuits for each measurement function and its associated ranges. Table 2-1 lists the overload limits for each function and range.

Table 2-1. Input Overload Limits

FUNCTION SELECTED		RANGE SELECTED	INPUT TERMINALS	MAXIMUM INPUT OVERLOAD
V	DC	ALL RANGES	V/k Ω /S and COMMON	1000 Vdc or peak ac
	AC	20V, 200V, 750V		750V rms continuous
		2V, 200 mV		750V rms for no longer than 10 seconds
mA	DC or AC	ALL RANGES	mA and COMMON	Double fuse protected (2A, 250V fuse in series with a 3A, 600V fuse) when measurements are made in circuits having open circuit voltage of 600V or less.
10A (8010A)		N/A	10A and COMMON	12A maximum Not fused.
k Ω or S		ALL RANGES	V/k Ω /S and COMMON	300V dc or ac rms.
LO RANGE Ω (8012A)		Both ranges	LO RANGE Ω and COMMON	300V dc or ac rms.

2-15. Fuse Replacement

2-16. The mA function of your meter is protected by a 2A, 250V fuse in series with a 3A, 600V fuse. If measurements are made in circuits with an open circuit voltage of 250V or more, the 2A fuse will blow first. Should the current rating (3A) be exceeded and the open circuit voltage of the circuit being measured exceed 250V, the second fuse will blow protecting the circuitry of your instrument. Should one or both blow, here is how to change them.

1. The 2A/250V fuse located behind the front panel should blow first. Use the following procedure to change it:

a. Insert a large coin or your thumbnail in the slot in the collar of the mA input terminal.

b. Turn the collar about 1/4 turn counterclockwise. (The direction shown by the arrow to the left of the mA input terminal). The collar should pop out about 1 cm.

c. Pull the collar out of the instrument. The 2A/250V fuse is in the holder on the back of the collar. Replace it with an AGX 2A/250V fuse or the European equivalent (see Section 5).

d. Insert the collar/fuse assembly back into the front panel.

e. With your fingertip, push the collar all the way into the front panel and turn it clockwise until the collar will turn no farther (about 1/4 turn).

2. The 3A/600V fuse is located in a clip holder on the Main PCB inside the instrument. Use the following procedure to change it:

a. Place the POWER switch in the OFF position.

b. Disconnect the power cord from the rear of your instrument.

c. Unscrew the phillips screw on the rear of the instrument.

d. Slide the instrument cover back until it comes clear of the inside of the instrument.

e. Holding the inside of the instrument by the edge of the front panel, turn the inside of the instrument over.

f. Looking down at the Main PCB from the front of the instrument, the fuse is located on the left side of the Main PCB halfway back.

NOTE

If you are unfamiliar with this type of fuse, there are component location diagrams of the Main PCB in both Sections 5 and 8.

g. Remove the fuse from the clip and replace it with a type BBS 3A fuse.

h. Turn the inside of the instrument right-side-up.

i. Slide the instrument cover back onto the instrument. Be careful to line up all guides.

k. On the rear of the instrument, screw the phillips screw back in.

l. Plug the power cord back into the receptacle on the rear of your instrument.



2-17. Making Voltage Measurements

2-18. In Section 1, we discussed the operation of the controls and terminals used to make voltage measurements. To use your instrument effectively, there are other factors of which you should be aware. Some of these factors will not normally affect your instrument and will be covered later as AC Measurement Considerations.

2-19. Your instrument has five ac voltage and five dc voltage ranges: 200 mV, 2V, 20V, 200V and either 750V ac or 1000V dc. All of these ranges present an input impedance of 10 M Ω . On the ac ranges, this input impedance is shunted by less than 100 pF. When you make the voltage measurements, be sure you do not exceed the overload limits listed in Table 2-1.

2-20. CONVERTING VOLTAGE MEASUREMENTS

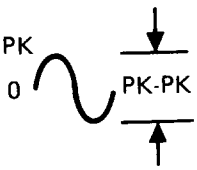
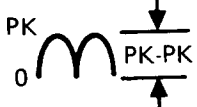
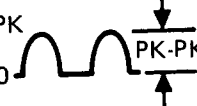
2-21. Your instrument is one of the new family of Fluke meters that actually measure the true rms value of an ac signal. This is a feature that allows accurate measurement of standard waveforms like distorted or mixed frequency sine waves, square waves, sawtooths, noise, pulse trains (with a duty cycle of at least .1), etc. In the past, the methods of ac measurement used have introduced large errors in the readings. Unfortunately, we've all grown used to these erroneous voltage readings and depend upon them to indicate whether or not a piece of equipment is working correctly. The data contained in Figure 2-1 should help you to convert between different measurement methods for the waveforms shown.

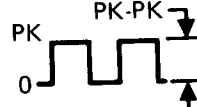
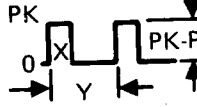
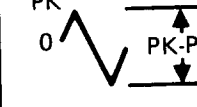
AC-COUPLED INPUT WAVEFORM	PEAK VOLTAGES		METERED VOLTAGES			DC AND AC TOTAL RMS
	PK-PK	0-PK	AC COMPONENT ONLY		DC COMPONENT ONLY	TRUE RMS = $\sqrt{ac^2 + dc^2}$
			RMS CAL *	8010A 8012A		
SINE 	2.828	1.414	1.000	1.000	0.000	1.000
RECTIFIED SINE (FULL WAVE) 	1.414	1.414	0.421	0.435	0.900	1.000
RECTIFIED SINE (HALF WAVE) 	2.000	2.000	0.764	0.771	0.636	1.000
SQUARE 	2.000	1.000	1.110	1.000	0.000	1.000
RECTIFIED SQUARE 	1.414	1.414	0.785	0.707	0.707	1.000
RECTANGULAR PULSE  $D = X/Y$ $K = D - D^2$	2.000	2.000	2.22K	2K	2D	$2\sqrt{D}$
TRIANGLE SAWTOOTH 	3.464	1.732	0.960	1.000	0.000	1.000

* RMS CAL IS THE DISPLAYED VALUE FOR AVERAGE RESPONDING METERS THAT ARE CALIBRATED TO DISPLAY RMS FOR SINE WAVES

Figure 2-1. Voltage Conversion

2-22. CIRCUIT LOADING ERROR

2-23. Connecting any voltmeter to a circuit changes the operating voltage of the circuit (loads the circuit down). As long as the circuit resistance (source impedance) is small compared to the input impedance of the meter, the error is not significant. For example, when measuring voltage with your meter, as long as the source impedance is 10 k Ω or less, the error will be $\leq 0.1\%$. If circuit loading does present a problem, the percentage of error can be calculated using the appropriate formula in Figure 2-2.

2-24. COMBINED AC AND DC SIGNAL MEASUREMENT

2-25. The waveform shown in Figure 2-3 is a simple example of an ac signal riding on a dc level. To measure waveforms such as these, first measure the rms value of the ac component using the AC function of your meter. Measure the dc component using the DC function of your instrument. The relationship between the total rms value of the waveform and the ac component and the dc component is:

$$\text{RMS Total} = \sqrt{(\text{ac component rms})^2 + (\text{dc component})^2}$$

1. DC VOLTAGE MEASUREMENTS

Loading Error in % = $100 \times R_s \div (R_s + 10^7)$
Where: R_s = Source resistance in ohms of circuit being measured.

2. AC VOLTAGE MEASUREMENTS

First, determine input impedance, as follows:

$$Z_{in} = \frac{10^7}{\sqrt{1 + (2\pi F \cdot R_{in} \cdot C)^2}}$$

Where: Z_{in} = effective input impedance
 R_{in} = 10^7 ohms
 C_{in} = 100×10^{-12} Farads
 F = frequency in Hz

Then, determine source loading error as follows:

$$\text{Loading Error in \%} = 100 \times \frac{Z_s}{R_s + Z_{in}}$$

Where: Z_s = source impedance
 Z_{in} = input impedance (calculated)
 R_s = source resistance

Figure 2-2. Circuit Loading Error Calculations

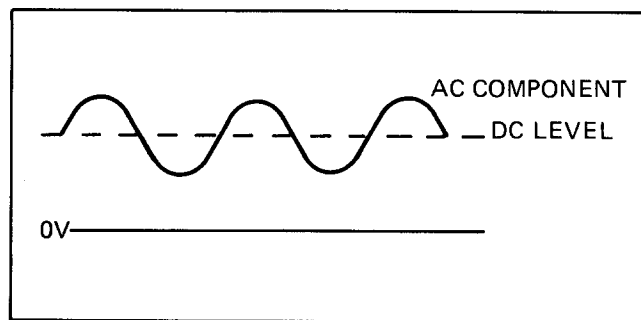

Figure 2-3. RMS Values

2-26. OFFSET

2-27. If you short the input of your meter while the AC voltage function is selected, you may have a reading of one or two digits on the display. This minute offset is caused by the action of amplifier noise and offset of the true rms converter. This offset will not significantly affect any readings until you try to measure signals almost at the floor of the meter. For example:

GIVEN: A dc offset over twice the normal maximum or offset = 5 digits.

$$\begin{aligned} \text{Input signal} &= 10 \text{ mV} \\ \text{Total RMS} &= \sqrt{(10)^2 + (.5)^2} \\ &= \sqrt{100.25} \\ &= 10.01 \text{ mV} \end{aligned}$$

but the meter will read this as:

$$\text{Total RMS} = 10 \text{ mV}$$

or using a realistic offset for your instrument,

GIVEN: offset = 2 digits.

$$\begin{aligned} \text{Input signal} &= 1 \text{ mV} \\ \text{Total RMS} &= \sqrt{1^2 + .2^2} \\ &= \sqrt{1.04} \\ &= 1.02 \text{ mV} \end{aligned}$$

The meter will read this as 1.0 mV.

2-28. NOISE ERRORS

2-29. Many noise errors in dc voltage measurements are due to the line power frequency coupling into the circuit. Design features of your instrument have a noise rejection of approximately 60 dB (cut the noise to 1/1000 of its original level) when operated in the line-frequency environment it is designed for. The decal on the bottom of your instrument will be marked for the line-frequency that your instrument will reject (50 Hz or 60 Hz). Instruments are available with a switch selectable line-

frequency circuit. If you have this type of instrument and wish to change the selected line-frequency rejection, remove the outer cover as described under Fuse Replacement and place S3 in the appropriate position. The component location diagrams of the Main PCB in section 5 and 8 show the location of S3.

2-30. Making Current Measurements

2-31. Both the 8010A and 8012A have five ac and five dc current ranges: 200 μ A, 2 mA, 20 mA, 200 mA, and 2000 mA. In addition, the 8010A has a 10A current measurement function. In both instrument, the five lower ranges are diode protected up to 2 amps and fuse protected above 2 amps. If either or both of the protective fuses blow, refer to the Fuse Replacement information presented earlier in this section. The 10A function on the 8010A is unfused, but will safely carry currents up to 12A or to the limits of the test leads.

2-32. When a meter is placed in series with a circuit to measure current, you may have to consider an error caused by the voltage drop across the meter (in this case, across the protective fuses and current shunts). This voltage drop is called burden voltage. The full scale burden voltages for your instrument are: 0.3V for the four lowest ranges, 0.9V for the 2000 mA range, and 0.5V for the 10A range on the 8010A. These voltage drops can affect the accuracy of a current measurement if the current source is unregulated and the resistance of the shunt and fuse represents a significant part (1/1000 or more) of the source resistance. If burden voltage does present a problem, the percentage error can be calculated using the formulae in Figure 2-4. This error can be minimized by selecting the highest current range that provides the necessary resolution.

2-33. Making Resistance Measurements

2-34. Both the 8010A and the 8012A have six direct reading resistance ranges: 200 Ω , 2 k Ω , 20 k Ω , 200 k Ω , 2000 k Ω and 20 M Ω . In addition, the 8012A offers a 2 Ω and a 20 Ω range on the LO RANGE Ω function.

2-35. Your instrument uses the two wire measurement techniques, so the readings will be in error by the amount of the resistance of your test leads. A pair of standard test leads has a combined lead resistance on the order of 0.2 Ω to 0.3 Ω . This low resistance only effects readings on your meter in the ranges below 2 k Ω . The LO RANGE Ω function of the 8012A has a ZERO adjustment to compensate for lead resistance. After selecting the 2 Ω range, make a firm contact between the sampling ends of the test leads and adjust the ZERO control until the LCD displays zero. The 200 Ω range has no compensation for lead resistance. Short the sampling ends of the test leads

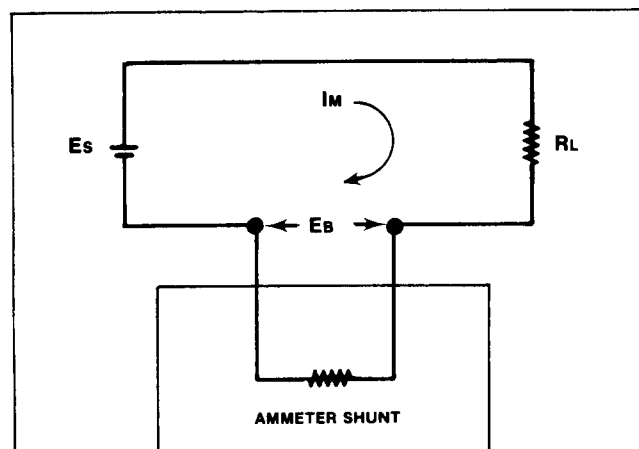

E_S = Source voltage
 R_L = Load resistance + Source resistance
 I_M = Measured current (display reading in amps)
 E_B = Burden voltage (calculated), i.e. Display reading expressed as a % of full scale ($100 \times \frac{\text{READING}}{\text{FULL SCALE}}$) times full scale burden voltage for selected range. See table.

RANGE	F.S. BURDEN VOLTAGE
2 mA to 200 mA	0.3V
2000 mA	0.9V
10A	0.5V

Current error due to Burden Voltage

$$\text{IN \%} = 100 \times \frac{E_B}{E_S - E_B}$$

$$\text{IN AMPS} = \frac{E_B \times I_M}{E_S - E_B}$$

Example: $E_S = 14\text{V}$, $R_L = 9\Omega$, $I_M = 1.497\text{A}$,

$$E_B = 100 \times \frac{1497}{2000} \times 0.9 \text{ (from Table)} =$$

$$74.9\% \text{ of } 0.9 = 0.674\text{V}$$

$$\text{Error in \%} = 100 \frac{.674}{14 - .674} = 100 \frac{.674}{13.326} = 5.06\%$$

Increase displayed current by 5.06% to obtain true current.

$$\text{Error in amps} = \frac{.674 \times 1.497}{14 - .674} = \frac{.991}{13.326} = 0.074\text{A}$$

Increase displayed current by 0.074A to obtain true current

Figure 2-4. Calculating Burden Voltage Error

together and read the lead resistance. When making resistance measurements, subtract the measured lead resistance and you will have an accurate resistance value.

2-36. The three resistance ranges with a diode symbol beside the range value have a high enough open circuit voltage to turn on a silicon junction. These ranges (2 k Ω , 200 k Ω , and 20 M Ω) can be used to check silicon diodes and transistors. The 2 k Ω range is preferred. It is marked with the largest diode symbol. On the other ranges, the voltage is too small to turn on silicon junctions. Use these ranges to make in circuit resistance measurements.

2-37. The range and resolution of the LO RANGE Ω function of the 8012A allows the measurement of such things as ballast resistors, transformer windings, heating elements, coils, relay contact resistance, fuses, etc. Readings can be made down to a few milliohms.

2-38. Making Conductance Measurements

2-39. There are three conductance ranges on your meter; 2 mS, 20 μ S, and 200 nS. You can think of this function either as a new type of measurement or as another way to measure high resistances. As a high resistance meter, your Fluke offers many advantages over previous methods, including the ability to make these high resistance readings at voltages within the operating range of IC's and MOS devices. As a conductance meter, your instrument can measure directly inverse function components. For example, the resistance of a photo-diode decreases as the available light increases. When using conductance, both parameters change together allowing easier, less error prone applications. The display is in conductance units, Siemens. If resistance readings are desired, refer to the conductance-to-resistance conversion information in Figure 2-5.

2-40. The 200 nS range can be used for making resistance measurements from 5 M Ω to 10,000 M Ω . Since conductance is the inverse of resistance, as the resistance measured increases, accuracy and measurement decrease so resolution noise problems decrease. Using a standard high-resistance meter in this range requires careful shielding to prevent noise pick-up. With your meter, standard test leads are all you need. Except for high voltage stress testing, this range of conductance replaces the megger and can be used to check high value resistors and low leakage components like diodes or capacitors. For more information, refer to the Applications material presented later in this section.

2-41. The 20 μ S range can be used for making resistance measurements from 50 k Ω to 100 M Ω . This range of conductance is the one best suited for measuring inverse resistance components such as phototransistors. For

more information, refer to the Applications material presented later in this section.

2-42. The 2 mS range can be used for making resistance measurements from 500 Ω to 1 M Ω . It can be used either for resistance measurements or for such things as direct-reading dc current gain (Beta) measurements on transistors. Beta measurement require a special test fixture presented in the Applications material later in this section.

2-43. The three conductance ranges span resistance measurements of 500 Ω to 10,000 M Ω . When using Ohm's law to determine current or power, it is sometimes necessary to divide by the resistance of the circuit or component. You may find it more convenient to measure conductance and multiply.

2-44. AC Measurement Considerations

2-45. When making precise measurements of ac signals, there are special parameters that must be considered such as the type of ac converter the meter uses (average, rms, etc.), crest factor, bandpass, noise, etc.

2-46. TRUE RMS

2-47. In order to compare dissimilar waveforms or calculate Ohm's law statements, or power relationships, you must know the effective value of a signal. If it is a dc signal, the effective value equals the dc level. If the signal is ac, however, we have to borrow the root mean square technique from the world of statistics in order to find the effective value of the signal. In electronics, this effective value is called the root mean square or rms value of the signal. Classically, the rms value of a current or voltage is defined as being numerically equal to the dc current or voltage that produces the same heating effect in a given resistance that the ac current or voltage produces.

2-48. In the past, average responding converters were the type of converter most widely used. Theoretically, the rms value of a sine wave is $1/\sqrt{2}$ of peak value and the average value is $2/\pi$ of the peak value. Since the meters converted to the average value, the rms value was $1/\sqrt{2} \div 2/\pi = \pi/2\sqrt{2} = 1.11$ of the average value when measuring a sine wave. Most meters used an average responding converter and multiplied by 1.11 to present true rms measurements of sine waves. As the signal being measured deviated from a pure sine wave the errors in measurement rose sharply. Signals such as square waves, mixed frequencies, white noise, modulated signals, etc. could not be accurately measured. Rough correction factors could be calculated for ideal waveforms if the signal being measured was distortion free, noise-free, and a standard waveform. The true rms converter in your meter provides direct, accurate measurement of these and other signals.

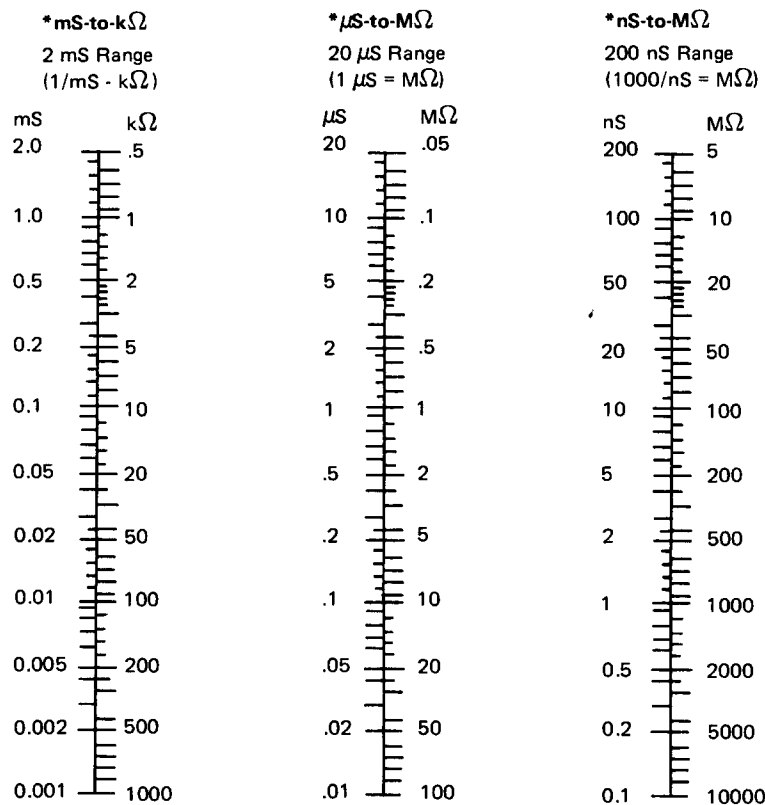

Conversion Scales
 * S = siemens = 1/Ω = International unit
 of conductance formerly known as the mho.

Find the approximate resistance value using one of the conversion scales. Then, on the Interpolation Table, locate the most significant digit of the display reading on the vertical NO. column, and the next digit on the horizontal NO. row. The number at the intersecting coordinates represents the unknown resistance value. For example, a reading of 52.0 nS is equal to 19.2 MΩ. Decimal point location is determined from the scale approximation.

Interpolation Table (I/no.)

NO.	.0	.1	.2	.3	.4	.5	.6	.7	.8	.9
1	1	.909	.833	.769	.714	.667	.625	.588	.556	.526
2	.500	.476	.455	.435	.417	.400	.385	.370	.375	.345
3	.333	.323	.313	.303	.294	.286	.278	.270	.263	.256
4	.250	.244	.238	.233	.227	.222	.217	.213	.208	.204
5	.200	.196	.192	.187	.185	.182	.179	.175	.172	.169
6	.167	.164	.161	.159	.156	.154	.152	.149	.147	.145
7	.143	.141	.139	.137	.135	.133	.132	.130	.128	.127
8	.125	.123	.122	.121	.119	.118	.116	.115	.114	.112
9	.111	.110	.109	.108	.106	.105	.104	.103	.102	.101

Figure 2-5. Conductance-to-Resistance Conversion

2-49. CREST FACTOR

2-50. Crest factor range is one of the parameters used to describe the dynamic range of a voltmeter's amplifiers. The crest factor of a waveform is the ratio of the peak to the rms voltage with the dc component removed. In waveforms where the positive and negative half cycles have different peak voltages, the higher voltage is used in computing crest factor. Crest factors start at 1.0 for a square wave (peak voltage equals rms voltage).

2-51. Your instrument has a crest factor range of 1.0 to 3.0. If an input signal has a crest factor of 3.0 or less, voltage measurements will not be in error due to crest factor limitations. If crest factor of a waveform is not known and you wish to know if it falls within the crest factor range of your meter, measure the signal with both your meter and an ac coupled oscilloscope. If the rms reading on your meter is 1/3 of the peak voltage on the waveform or less, then the crest factor is less than 3.0.

2-52. The waveforms in Figure 2-6 show signals with increasing values of crest factor. As you can see from the series of waveforms, a signal with a crest factor above 3.0 is unusual.







WAVEFORM	CREST FACTOR
SQUARE WAVE 	1.0
SINE WAVE 	1.414
TRIANGLE SAWTOOTH 	1.732
MIXED FREQUENCIES 	1.414 to 2.0
SCR OUTPUT OF 100% - 10% 	1.414 to 3.0
WHITE NOISE 	3.0 to 4.0
PULSE TRAIN 	3.0
PULSE TRAIN $D < .012$ 	> 9.0

Figure 2-6. Crest Factor

2-53. Rectangular waves, as usual, have their own special formula. It is:

$$\text{Crest Factor} = \sqrt{1/D - 1}$$

Where D = duty cycle or the ratio of pulse width to cycle length. Using this formula backwards, we find that your meter can accurately measure pulse trains with a duty cycle above 10% without being limited by crest factor.

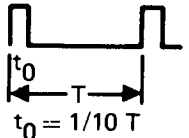
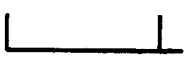
$$\begin{aligned} \text{Crest Factor} = 3.0 &= \sqrt{1/D - 1} \\ 9.0 &= 1/D - 1 \\ 10.0 &= 1/D \\ D &= 1/10 = 10\% \end{aligned}$$

2-54. BANDWIDTH

2-55. Bandwidth defines the range of frequencies where attenuation by the voltmeter's amplifiers and filters is no more than 3 dB down (half power levels). Your instrument has a bandwidth of up to 200 kHz on the 200 mV and 20V ranges and at least twice that on the 2V and 200V ranges. For brevity, let's call the bandwidth of your meter 200 kHz for these discussions.

2-56. SLEW RATE

2-57. Slew rate is also called the rate limit or the voltage velocity limit. It defines the maximum rate of change of the amplifiers for a large input signal.

2-58. RISE AND FALL TIME EFFECT ON ACCURACY

2-59. The rise and fall times of a waveform are the length of time it takes a waveform to change between the points that are 10% and 90% of the peak value. When discussing these periods, we'll only mention rise time. Errors due to rise or fall time can be caused either by bandwidth or slew rate. Slew rate should not affect your measurement with either the 8010A or the 8012A.

2-60. A good rule-of-thumb for converting the effects of bandpass into a rise time limit is to divide 0.35 by the high frequency value at the 3 dB point. For your instrument this will be $0.35 / 200k = 1.75 \mu\text{sec}$. The following example will help you to calculate errors due to this limitation when measuring rectangular pulses. These calculations will be rough because ideal waveforms are used in the analysis.

2-61. Ideally, the rectangular pulses would have zero rise and fall times and would be the right angled waveform shown in Figure 2-7, Part A. In practice, every waveform has a rise and fall time and looks more like the waveform in Figure 2-7, Part B. When calculating the error caused by the bandpass of your instrument, we will

assume worst case conditions, where the rise and fall times equal the effect caused by bandpass - 1.75 μsec . To do this, we will calculate the values for the theoretical signal with zero rise and fall times then calculate the values for a signal with the same period but with total slope periods equal to 1.75 μsec . A comparison of the results will show the measurement error due to the bandpass.

2-62. Let's look at the waveform in Figure 2-7, Part B. When using your meter to measure the ac component of the signal, the display will indicate the rms value of the ac signal riding on the dc level. (This dc level is the average value of the waveform when considered from the baseline.) The total rms value of the waveform can be calculated using the relationship:

$$E_{\text{total rms}} = \sqrt{E_{\text{ac rms}}^2 + E_{\text{dc}}^2}$$

There are long established formula for computing the dc level and total rms values. Using Figure 2-7, Part B, for a reference, these formulae are:

$$E_{\text{total rms}} = A \sqrt{\frac{3t_o + 2t_l}{3T}}$$

$$E_{\text{dc}} = A \left(\frac{t_o + t_l}{T} \right)$$

Since we can calculate two values, to find what your meter measures, use the formula:

$$E_{\text{ac rms}} = \sqrt{(E_{\text{total rms}})^2 - (E_{\text{dc}})^2}$$

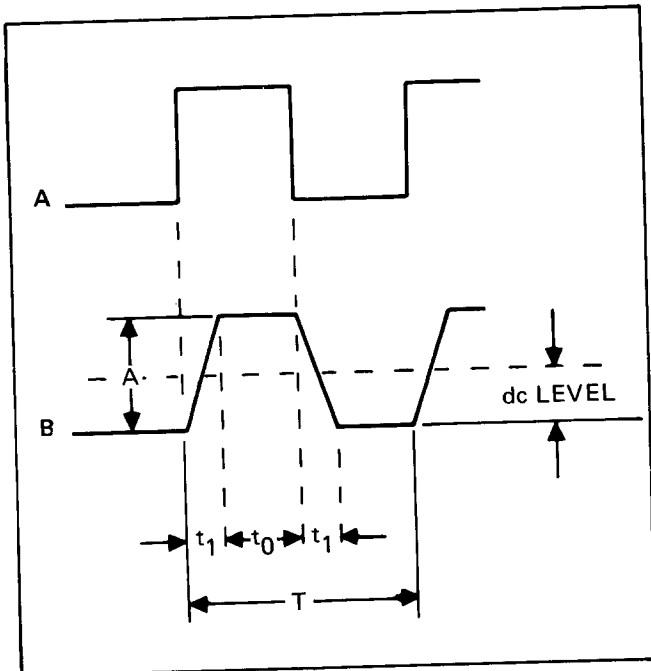

Figure 2-7. Components of a Rectangular Waveform

2-63. For our example let's use a 10 kHz pulse train with 50 μsec pulses at a peak value of 1V. Ideally, the pulses would have a zero rise time as shown in Figure 2-8, A.

$$E_{\text{total rms}} = \sqrt{\frac{3(50) + 2(0)}{3(100)}} = \sqrt{\frac{150 + 0}{300}} = \sqrt{\frac{1}{2}}$$

$$E_{\text{total rms}} = 0.707$$

$$E_{\text{dc}} = 1 \left(\frac{50 + 0}{100} \right) = \frac{50}{100} = 0.5$$

$$\text{So, the } E_{\text{ac rms}} = \sqrt{(0.707)^2 - (0.5)^2} = \sqrt{0.50 - 0.25}$$

$$E_{\text{ac rms}} = \sqrt{0.25} = 0.5$$

When the maximum distortion in rise time of 1.75 μsec is assumed, the signal becomes the isosceles trapezoid waveform shown in Figure 2-8, Part B. In this case,

$$E_{\text{total rms}} = \sqrt{\frac{3(48.25) + 2(1.75)}{3(100)}} = \sqrt{\frac{144.75 + 3.50}{300}}$$

$$E_{\text{total rms}} = \sqrt{\frac{148.25}{300}} = \sqrt{0.494} = 0.703$$

$$E_{\text{dc}} = 1 \left(\frac{48.25 + 1.75}{100} \right) = \frac{50}{100} = 0.50$$

$$\text{So, } E_{\text{ac rms}} = \sqrt{(0.703)^2 - (0.50)^2} = \sqrt{0.494 - .25}$$

$$E_{\text{ac rms}} = \sqrt{0.244} = 0.494$$

Note that the E_{dc} stayed the same.

So, the errors are:

In $E_{\text{total rms}}$: - 0.6%

In $E_{\text{ac rms}}$: - 1.2%

2-64. OPERATION

2-65. Operation of your instrument is easy:

1. Set the POWER switch to ON.
2. Set the function and range switches to the correct position for the measurement being made. (Refer to Section 1.)
3. Connect the test leads to the appropriate terminals. (Refer to Section 1.)

NOTE

When making LO RANGE Ω measurements, zero the test lead resistance.

- Contact the input signal with the sampling ends of the test leads and read the display.

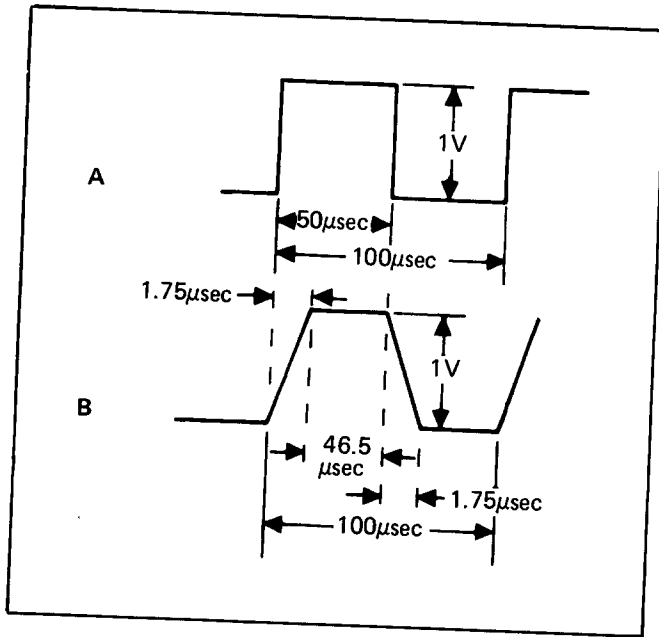

Figure 2-8. Example

2-66. APPLICATIONS

2-67. The test applications described in the following paragraphs are suggested as useful extensions of your meter's measurement capabilities. They are not meant to be the equivalent of manufacturer's recommended test methods. They are intended to provide you with repeatable, meaningful indications which will allow you to decide whether the device being tested is good, marginal, or defective.

2-68. Transistor Tester

NOTE

The transistor tester described in the following paragraphs provides approximate test information. Beta is measured using a VCE of about 2V and an IC of about 200 μ A. It is very useful for comparative measurements and matching.

2-69. Select the 2 mS range then plug the fixture shown in Figure 2-10 into the V/k Ω and COMMON input terminals, and you have transformed your instrument

into a transistor tester. Now, plug a transistor into the test socket and your meter will determine the following:

- Transistor type (NPN or PNP).
- Collector-to-emitter leakage (ICEs).
- Beta from 10 to 1000 without changing range.

2-70. Transistor type is determined by setting the switch on the fixture to BETA and observing the display. If a very low reading (≤ 0.010) is obtained, reverse the test fixture at the input terminals. If the collector is now positioned at the COMMON input terminal, the transistor is a PNP type. An NPN type will have its collector positioned at the V/k Ω input terminals. If the transistor is defective the indications will be as follows regardless of fixture position:

- A shorted transistor will cause an overload indication.
- An open transistor will read 0.001 or less.

2-71. After the transistor fixture is properly positioned, set the switch to ICEs for the leakage test. The transistor is turned off in this test (base shorted to emitter), and should appear as a very low conductance (high resistance) for collector-to-emitter. Therefore, the lower the reading, the lower the leakage. Silicon transistors that read more than 0.002 (6 μ A) should be considered questionable.

2-72. Beta is determined by setting the fixture switch to BETA, and observing the display. Mentally shift the decimal point three places to the right and read beta directly. For example, a display reading of 0.127 indicates a dc current gain (beta) of 127.

NOTE

Beta is a temperature sensitive parameter. Therefore, repeatable readings can only be obtained by allowing the transistor to stabilize at the ambient temperature while being tested. Avoid touching the transistor's case with your fingers.

2-73. Leakage Tester

2-74. The 200 nS conductance range effectively extends the resistance measurement capability of the instrument (up to 10,000 M Ω) to the point where it can be used to provide useful leakage measurements on passive components. For example, you can detect leaky capacitors, diodes, cables, connectors, printed circuit boards (pcb's), etc. In all cases, the test voltage is <5V dc.

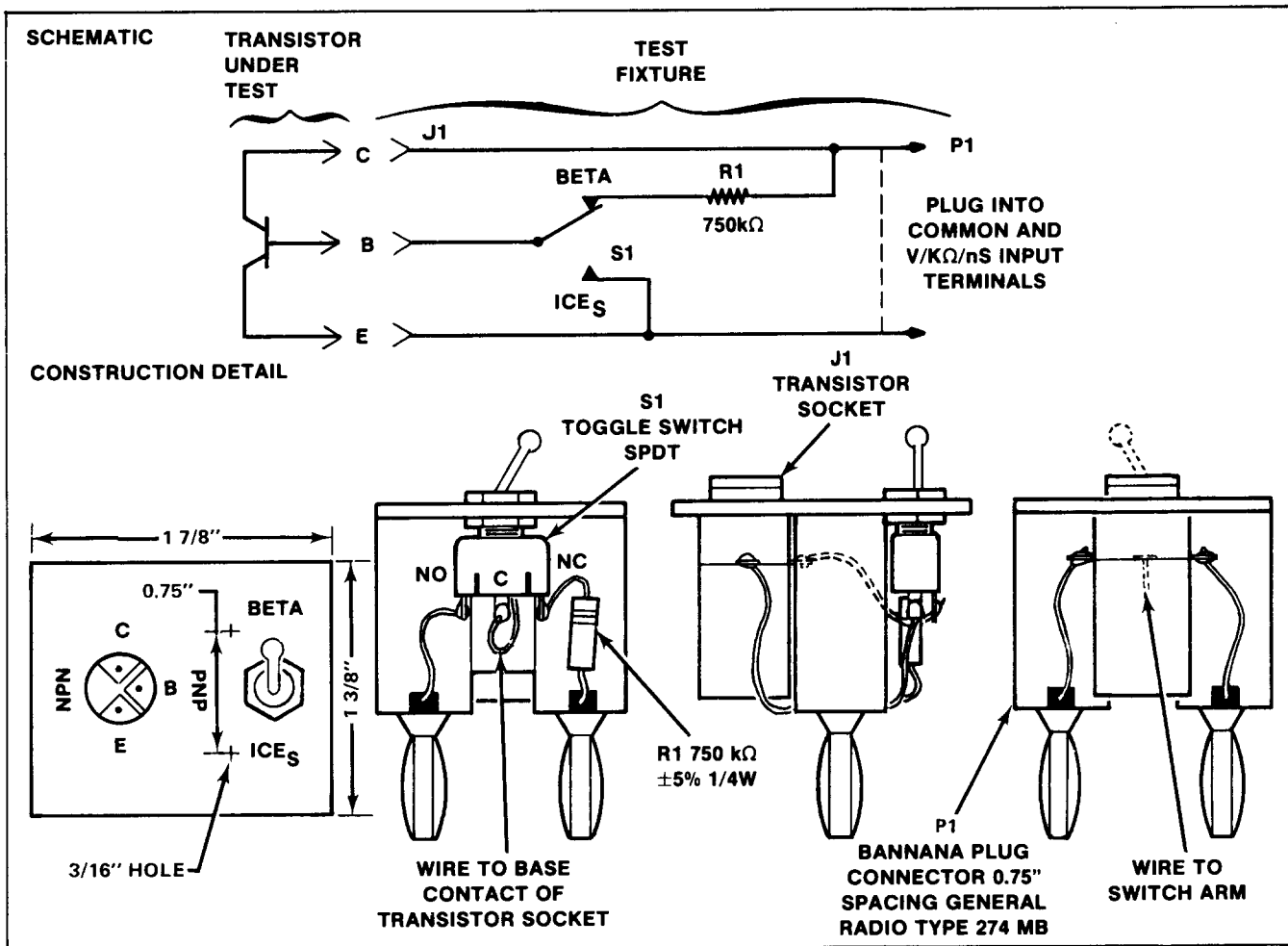

Figure 2-9. Transistor Beta Test Fixture

2-75. RESISTIVE COMPONENTS

2-76. Leakage testing on purely resistive components such as cables and pcb's is straight forward. Select the 200 nS range, install the test leads in the V/kΩ and COMMON input terminals, connect the leads to the desired test points on the unit-under-test, and read leakage conductance. If an overrange occurs, select the resistance range that provides an on-scale reading.

NOTE

Under high humidity condition (>80%) conductance measurements may be in error. To ensure accurate measurement connect clean test leads to the instrument and (with the leads open) read the residual leakage in nanosiemens. Correct subsequent measurements by subtracting this residual from the readings. (Finger prints or other contamination on the pcb may also cause residual conductance readings).

2-77. DIODES

2-78. Diode leakage (IR) tests require that the diode junction be reverse biased when being measured. This is accomplished by connecting the diode's anode to the COMMON input terminal and its cathode to the V/kΩ input terminal. Leakage can then be read in terms of conductance. In the event of an overrange, select a resistance range that provides an on-scale reading.

2-79. Relative Light Meter

2-80. A photodiode or phototransistor soldered across a double banana connector can be plugged into the COMMON and V/kΩ/S input terminals of your instrument. The 20 μS range on your instrument measures the inverse of the resistance range from 50 kΩ to 100 MΩ - the resistance range of most photodiodes and phototransistors. The resistance of the photo-sensitive device is inversely proportional to the available light. That is, as the available light increases, the resistance of the device decreases. By using conductance to keep track of the change in resistance, the readings are directly proportional to the change in available light. Experience will provide you with repeatable data ranges.

Section 3

Theory of Operation

3-1. INTRODUCTION

3-2. This section of the manual tells how your Fluke multimeter works. Even if you never repair or calibrate your own multimeter, understanding how it works will enable you to get the most out of your instrument. You'll find that the theory of operation is presented in two parts: a basic overall description of the functional sections of the instrument and a more detailed description of each functional section.

3-3. BASIC DESCRIPTION

3-4. As Figure 3-1 shows, the heart of your Fluke multimeter is a digital voltmeter that can measure DC voltages from $-2V$ to $+2V$ or $+200\text{ mV}$ to -200 mV very accurately. This voltmeter is composed of a custom IC and the LCD (Liquid Crystal Display). The custom IC contains an analog/digital converter, a controller, and the LCD drivers. An unknown analog voltage is converted to a digital representation by the a/d converter. The controller calculates the value of the input in units of the selected function and range and controls the a/d converter. The LCD drivers display the computed value of the unknown input on the LCD.

3-5. The input signal conditioners convert the various input signals into a DC voltage between $\pm 2V$ or $\pm 200\text{ mV}$ that is proportional to the input. The rest of the circuitry either protects the multimeter from overloads and transients or produces the basic operating voltages for the instrument.

3-6. Digital Voltmeter

3-7. The custom IC, U3, and the $3\frac{1}{2}$ digit LCD are the digital voltmeter that is the heart of your instrument. The custom IC contains an a/d converter, a digital controller, and the display logic for the LCD. To function properly, the IC, U3, depends upon some external components to

establish basic timing and analog levels. Basic timing is established by a quartz crystal, Y1. Resistors, capacitors and an external voltage reference establish the analog levels for the a/d converter.

3-8. The digital voltmeter has two ranges of measurement. If you select either the 200 mV or $20V$ ranges or their equivalent ranges in other functions, the digital voltmeter can read voltages from -200 mV to $+200\text{ mV}$. Selection of any other range will enable the digital voltmeter to read $+2V$ to $-2V$.

3-9. A/D CONVERTER

3-10. The a/d converter uses the dual slope integration method. Dual slope integration takes advantage of the natural laws governing the charge and discharge of capacitors. Basically, in dual slope integration, an unknown voltage is applied to a capacitor for a specific length of time. Then a known voltage of the opposite polarity is applied to the capacitor and the time it takes for the capacitor to discharge is measured. The discharge time is proportional to the level of the unknown input voltage. This method is extremely accurate, fast and noise-free.

3-11. To see how your instrument performs dual slope integration, we'll assume your instrument is a 60 Hz version with a range selected that enables the $\pm 2V$ measurement function of the internal voltmeter. Figure 3-2 contains a simplified schematic of the a/d converter at the top and a timing diagram at the bottom. The circled switches in the simplified schematic represent FET switches operated by the digital controller. These FET switches and the three operational amplifiers are located inside U3. All other components are external to U3. The timing diagram shows the operation of the FET switches for one conversion cycle with unknown voltage inputs of $1/2$ range, full range and overrange. The conversion cycle is continuously repeated.

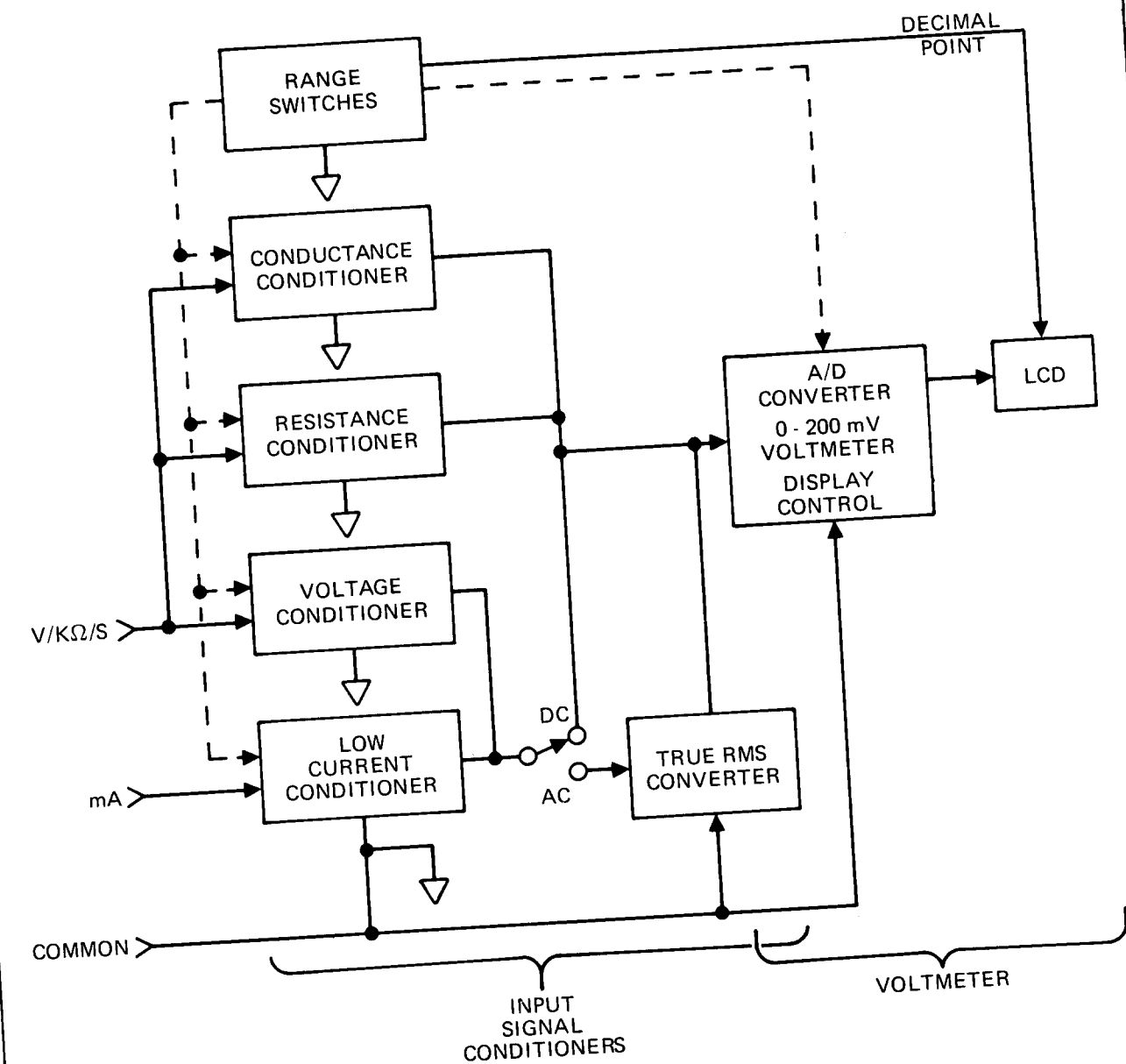

Figure 3-1. Basic Block Diagram

3-12. The basic clock frequency is 60 kHz. The 3.84 MHz from the quartz crystal is divided by 64 to produce the clock frequency. The timing diagram shown in Figure 3-2 uses the number of clock cycles counted as timing indicators. The conversion cycle is 20,000 cycles long or 1/3 of a second for the 60 Hz versions.

3-13. Let's put in an unknown voltage equal to 1/2 range and look at the a/d converter just before the integrate (INT) period begins. The auto-zero (AZ) is just

ending so the a/d converter should be ready to receive a new input. The controller opens the AZ FETs and closes the INT FET. The input to the integrator and the comparator changes. The integration capacitor, C1, starts to charge. The comparator no longer has matched inputs so its output (CM) drops to a lower level. The integrate period lasts for a count of 1000. At the end of this time, the controller will open the INT FET and close the READ FET. At this time, C1 is charged to a level proportional to the level of the unknown input voltage.

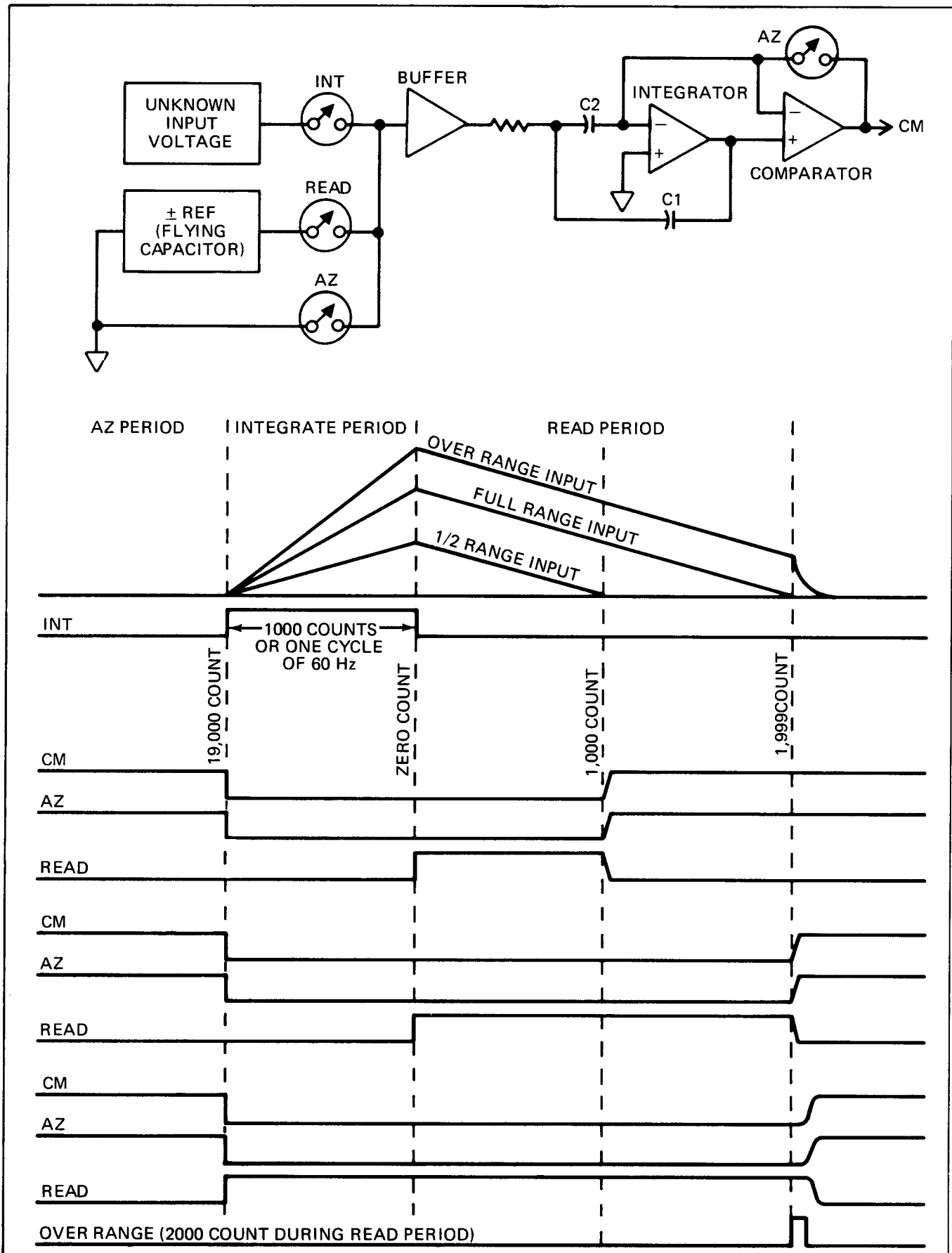

Figure 3-2. A/D Converter Simplified Schematic and Timing Diagram

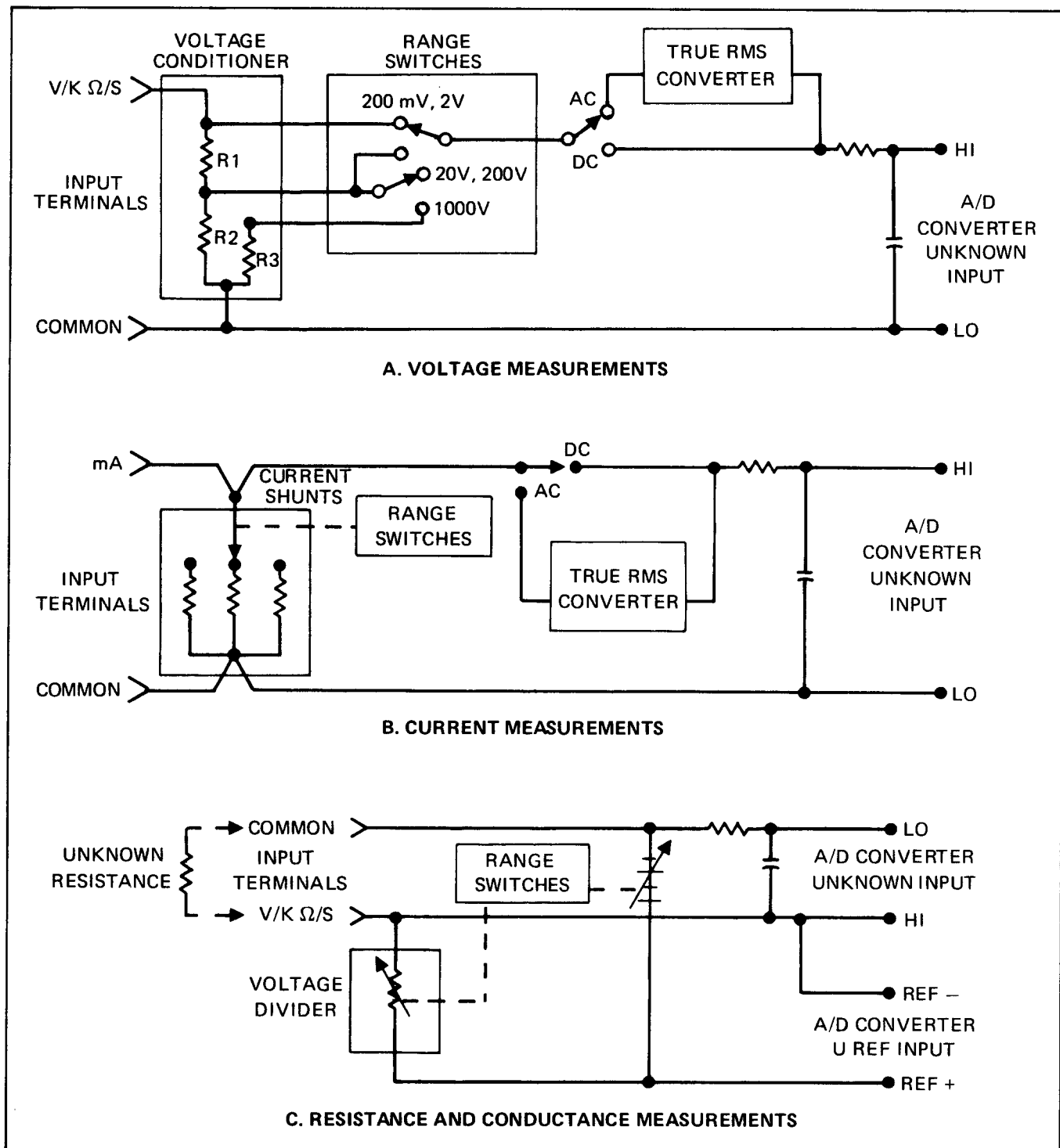

Figure 3-3. Input Signal Conditioners

your instrument when voltage measurements are being made. When either the 200 mV or the 2V range is selected, the input signal passes through the top range switch bypassing the voltage divider completely. (The appropriate measurement function of U3 will be enabled by the range switches too.) When either the 20V or 200V range is selected, the top range switch will be in the down position and the bottom range switch will be in the

position shown. The portion of the input signal between R1 and R2 is used by your instrument. The voltage divider ratio is 1/100. Signals on the 20V range can now be measured by the 2V function of U3. When the 1000 VDC (750 VAC) range is selected, both range switches are in the down position. This places R3 in parallel with R2. The voltage divider ratio is now 1/1000. The input signals can now be measured by the 2V function of U3.

3-31. Current Conditioner

3-32. The current conditioner changes the current signal input into a voltage representation. This is done by passing the unknown current through a precision resistor and measuring the voltage developed across the resistor. If the proper resistance is selected, the voltage out of the current conditioner will be within the range required by the a/d converter. These resistors are a special type of high power precision resistors known as current shunts. (They route the current or shunt the current around the meter.) Part B of Figure 3-3 is a simplified schematic of your meter's front end when current measurements are being made. The range switches determine the combination of current shunts used for each range. The five current shunts are precisely 1000Ω, 100Ω, 1.00Ω and .100Ω. The position of the AC/DC switch will determine the route the voltage output of the current conditioner takes to reach the input of the a/d converter.

3-33. The 10 Amp function of the 8010A routes the current being measured from the 10A input jack through a special current shunt of 0.01Ω. The voltage developed across the shunt goes through the AC/DC switch just like the voltage output of the current conditioner.

3-34. Resistance Conditioner

3-35. The resistance conditioner is the same voltage divider used in voltage measurements. In measuring voltage or current the appropriate input signal conditioner did all the conversion of the input signal, the rest of the meter just measured the output of the signal conditioner. The resistance measurement is more complex. The resistance conditioner is just used as a reference resistor.

3-36. Your Fluke meter uses the ratio method to measure the value of an unknown resistance. Part C of Figure 3-3 is a simplified schematic of your instrument's front end when making resistance measurements. The reference resistor is placed in series with the unknown resistance and V SOURCE is applied across them. The ratio of the resistances equals the ratio of the voltage drops across the respective resistances:

$$\frac{R_{\text{Unknown}}}{R_{\text{Reference}}} = \frac{E_{\text{Unknown}}}{E_{\text{Reference}}}$$

If we use the a/d converter to measure the voltage ratio, the value of the unknown resistance can be calculated.

3-37. The voltage drop across the unknown resistance is applied to the HI and LO inputs of the a/d converter. The voltage drop across the reference resistor is used as the reference voltage for the a/d converter. The range switches select the reference resistance (from the voltage divider) and V SOURCE so that the inputs to the a/d

converter stay within the proper range of U3. The reference resistance is designed so that the output of the a/d converter displayed on the LCD is the value of the unknown resistance.

3-38. Conductance Conditioner

3-39. The conductance conditioner is the same voltage divider that is used for measuring voltage or resistance. In fact, the whole method of measuring conductance is the same as for measuring resistance with one exception. The controller inside the custom IC commands the a/d converter to switch the unknown and reference voltage inputs. That is, the a/d converter will use the reference voltage during the integrate period and the unknown voltage during the read period. This inverts the voltage ratio so the reciprocal of resistance - conductance - is displayed in the LCD.

3-40. Range Switches

3-41. Though the range switches are not exactly input signal conditioners, we've seen that they do control the input signal conditioners so that the inputs to your meter can be processed properly. In addition to the functions we've already discussed, the range switches also position the decimal point so that the LCD display is the correct value.

3-42. MISCELLANEOUS CIRCUITRY

3-43. Meter Protection Circuits

3-44. Have you ever tried to measure voltage with a resistance range selected on your meter? Or have you tried to measure 6.5V on pin 15 only to find that someone had wired pin 15 to the 1200V source that should have been wired to pin 16? Most of us have. At times like these, meter protection circuits are essential. The protection circuits in your Fluke multimeter will allow your instrument to absorb an unreasonable amount of abuse without affecting its performance. With more catastrophic inputs, these protection circuits will fail safely, protecting the more vital sections of your meter. We'll use the schematic of the Main PCB located in Section 8 to illustrate the description of the meter protection circuitry.

3-45. VOLTAGE MEASUREMENT PROTECTION

3-46. When the voltage measurement function is selected, your Fluke meter can tolerate voltage inputs of slightly more than the highest input range no matter what range is selected. If the input voltage is higher than the limits of the range selected, an overrange indication will be displayed. Once the input voltage exceeds about 1200V, the resistance of the three varistors (RV1, RV2, and RV3) drops, clamping the meter side of R2 to 1200V.

These varistors can compensate for abusive transient voltage inputs of up to 6000V. Should the input voltage exceed even this unreasonable level and generate enough heat to destroy R2; R2 is a flame-proof resistor. R16 is a 1 M Ω , 1W, current limiting resistor that will protect U3 from dc voltage inputs of up to 1000V (handy if a low range is selected). R14 is a 100 k Ω , 2W, current limiting resistor that will protect the input buffer of the rms converter for inputs of 750V rms or 1000V peak continuous for the 200 mV and 2V ranges. On these two ranges, high level input applied for longer than the 10 second maximum listed in the Specification Table may cause damage to or failure of the resistor. The input divider attenuation provides additional protection on all other ranges.

3-47. RESISTANCE/CONDUCTANCE MEASUREMENT PROTECTION

3-48. Selecting either the resistance or conductance measurement function places Q1, Q2 and RT1 in parallel with the meter across the resistance input and common lines. These three components provide protection for inputs up to 300V.

3-49. The LO RANGE Ω function of the 8012A has separate protection circuitry rated at 300V input. Referring to the Low Ohms schematic in Section 8, the circuitry is in two parts, 10 mA current source and the functional op amp circuit. The op amp input is protected up to 300V by R59, CR51 and CR52. The 10 mA current source is protected by the action of the circuit formed by R51, R52, Q51 and Q52. This circuit can withstand up to 700V. CR50 protects the current source from negative voltages.

3-50. CURRENT MEASUREMENT PROTECTION

3-51. The mA input is protected two ways. CR1 and U4 limit the voltage drop across the current shunts. F1 and F2 protect the current shunts from overcurrent conditions. F1 is a fast blowing fuse rated for 2A at 250V. It is the type with a wire thread in an evacuated glass envelope. Under moderately abusive overloads, F1 will blow protecting the circuitry. But if the overload voltage is high enough, the voltage will arc through the metal vapor caused by F1 blowing. F2 will blow in this case. F2 is rated for 3A at 600V.

3-52. The 10A function of the 8010A has no fuse protection circuitry. It can handle overloads of up to 12A.

3-53. Power Supply

WARNING

LINE VOLTAGE POTENTIAL IS ON THE PRIMARY POWER CIRCUIT ANY TIME THE INSTRUMENT IS PLUGGED IN TO A LINE POWER OUTLET.

3-54. The standard instrument can be ordered with a power supply made to operate from 115V, 60 Hz; 100V 50 Hz or 60 Hz selectable; and 230V, 50 Hz. This power supply provides all basic operating voltages for the instrument. These voltages are rectified and filtered but are not regulated. All regulated voltage needs are supplied either by U7 or by the custom IC, U3. The POWER switch opens the secondary circuit. The power supply transformer, T1, is a special self-limiting transformer so the input is not fused.

3-55. A battery pack option for both instruments is available. This option will operate from 90-264V, 50 Hz or 60 Hz (selectable). Refer to the -01 option in Section 6 for additional information.

3-56. Touch and Hold Circuit

3-57. The touch and hold circuit allows the use of the optional Touch and Hold Probe with your instrument. Look at the schematic of the Main PCB in Section 8. The CL2 line to the crystal Y1 continues to the left, passing through Q4 and Q3 to ground. This path allows the crystal to oscillate. If a ground is applied to the mA terminal, Q3 is cut off. This stops the instrument clock. The last value displayed on the LCD remains displayed until the ground is removed from the mA terminal.

CAUTION

The Touch and Hold function is meant to be used for intervals of no more than a few minutes. If the display is stopped for longer periods of time (1/2 hour, 1 hour, etc.) the outline of the digits will remain for a few hours after the display is started again. If the display is stopped for extremely long periods of time, the LCD may be permanently damaged.

Section 4

Maintenance

WARNING

THESE SERVICE INSTRUCTIONS ARE FOR USE BY QUALIFIED PERSONNEL ONLY. TO AVOID ELECTRIC SHOCK, DO NOT PERFORM ANY SERVICING OTHER THAN THAT CONTAINED IN THE OPERATING INSTRUCTIONS UNLESS YOU ARE QUALIFIED TO DO SO.

4-1. INTRODUCTION

4-2. This section of the manual contains maintenance information for both the Model 8010A and the Model 8012A Digital Multimeters. This maintenance information is divided into service information, general maintenance, a performance test, a calibration procedure and troubleshooting. The performance test is recommended as an acceptance test when the instrument is first received, and later as a preventative maintenance tool to verify proper instrument operation. A 1-year calibration cycle is recommended to maintain the specifications given in Section 1. The test equipment required for both the performance test and calibration procedure is listed in Table 4-1. If the recommended equipment is not available, instruments having equivalent specifications may be used.

4-3. SERVICE INFORMATION

4-4. The 8010A and 8012A are both warranted for a period of 1-year upon delivery to the original purchaser. Conditions of the warranty are given at the rear of the manual.

4-5. Malfunctions that occur within the limits of the warranty will be corrected at no charge. Simply mail the instrument (post paid) to your nearest authorized (in-warranty) Fluke Technical Service Center. Shipping information and a complete list of service centers are provided in Section 7. Dated proof-of purchase will be required for all in-warranty repairs.

4-6. Factory authorized service centers are also available for calibration and/or repair of instruments that are beyond their warranty period. Contact your nearest authorized Fluke Technical Service Center for a cost quotation. Ship the instrument and your remittance using the instructions given in Section 7.

4-7. GENERAL INFORMATION

4-8. Access Information

NOTE

To avoid contaminating the pcb with oil from the fingers, handle it by the edges or wear gloves. If the pcb does become contaminated, refer to the cleaning procedures given later in this section.

4-9. CALIBRATION ACCESS

4-10. Use the following procedure to gain access to the calibration adjustments of your instrument.

1. Set the POWER switch to OFF.
2. Disconnect the power cord plug from the receptacle in the rear of the instrument.
3. Remove the phillips screw from the back of the instrument.
4. Slide the cover to the rear until the cover is free of the interior of the instrument.

Table 4-1. List of Recommended Test Equipment

INSTRUMENT TYPE	REQUIRED CHARACTERISTICS	RECOMMENDED MODEL
Multimeter Calibrator	DC Voltage: 0 to 1000V \pm .05% AC Voltage: 100 Hz - 0 to 200V \pm .05% 0 to 750V \pm .8% 1 kHz - 0 to 250V \pm .05% 10 kHz - 0 to 110V \pm .3% 50 kHz - 0 to 20V \pm .5% DC Current: 0 to 2000 mA \pm .04% AC Current: 0 to 200 μ A \pm .01% Resistance: 0 to 10 M Ω in steps of power-of-ten \pm .05%	John Fluke Model 5100A
DMM	Read true rms 0 to 12V \pm 1%	John Fluke Model 8010A, 8012A, 8012A, 8020A or 8000A
Calibration Leads	One red, one black - 24" spade lug to banana connector	Pomona 1987-24
Lo Ohms Calibration Lead	8 inch patch cord, male banana to male banana	Pomona 1985-8
19 Ohm Test Set 1.90 Ohm Test Set	19 \pm .05% Ω resistance 1.9 \pm .05% Ω resistance	See text on Special Test Devices presented later in this Section.

5. Turn the instrument upside down.
5. Unplug the seven wire cable.
6. All adjustments necessary to complete the calibration procedure are now accessible.
6. For reassembly, logically reverse this procedure.
7. For reassembly, logically reverse the procedure.
- 4-13. MAIN PCB ACCESS
- 4-11. LOW OHMS PCB ACCESS - 8012A ONLY
- 4-14. Use this procedure to remove the Main PCB.
 1. Perform the calibration access procedure.
 2. If you have an 8012A, perform the Low Ohms PCB access procedure.
 3. Remove the two screws from the rear of the bottom shield.
 4. Remove the bottom shield.
 5. Disconnect the front panel wires as follows:
 - a. The V/k Ω input line (white), the COMMON input line (black), and, in the
- 4-12. Use this procedure to remove the Low Ohms PCB.
 1. Perform the calibration access procedure.
 2. Remove all three screws holding the Low Ohms PCB down.
 3. Unplug the LO RANGE Ω input lead from the front panel terminal.
 4. Pull the zero adjustment knob off the extender shaft.

8010A, the 10A input line (purple) are all attached to the front panel by a snap connector. Unplug these lines.

b. The mA input line (white) is more difficult to remove. It may either be unsoldered from the Main PCB or the following procedure may be used:

1. On the front panel, insert a coin or your fingernail into the slot on the mA terminal, turn the mA terminal 1/4 turn counterclockwise. Remove the fuse and holder.
2. Bend a small hook in the end of a paper clip (or equivalent).

NOTE

Perform the rest of this procedure carefully so the plastic walls of the fuse holder are not damaged.

3. Pull the wire up through the fuse holder slot.
4. Keep tension on the wire so that the rear end of the spring is as shown in Figure 4-1, Part A.
5. Insert the hook on the paper clip as shown in Figure 4-1, Part A. Pry gently upward until a few turns of the spring are free of the fuse holder.
6. Grasp the spring as shown in Figure 4-1, Part B and turn counterclockwise until the spring comes completely free of the fuse holder.
7. Slide the spring down the wire to the Main PCB.

8. Push the wire back inside the slot in the fuse holder.

9. With the paper clip, pry the spring retainer free of the fuse holder as shown in Figure 4-1, Part C.

10. Pull the wire free of the slot in the fuse holder. Figure 4-1, Part D shows the mA input line free of the fuse holder.

11. Reinstall the fuse and fuse holder.

6. Turn the instrument right side up.

7. Remove the two screws at the rear of the top shield and lift the top shield away from the Main PCB.

8. Remove the two screws that connect the Main PCB and the Front Panel Assembly. The screws are located at the front of the instrument, right side.

9. Carefully pull the front panel free of the switches.

10. To replace the Main PCB, logically reverse this procedure being careful to install the pcb and the shields in their appropriate guides.

4-15. DISPLAY ACCESS

4-16. Use the following procedure to remove or replace the LCD.

1. Perform the calibration access procedure.
2. Turn the instrument right side up.

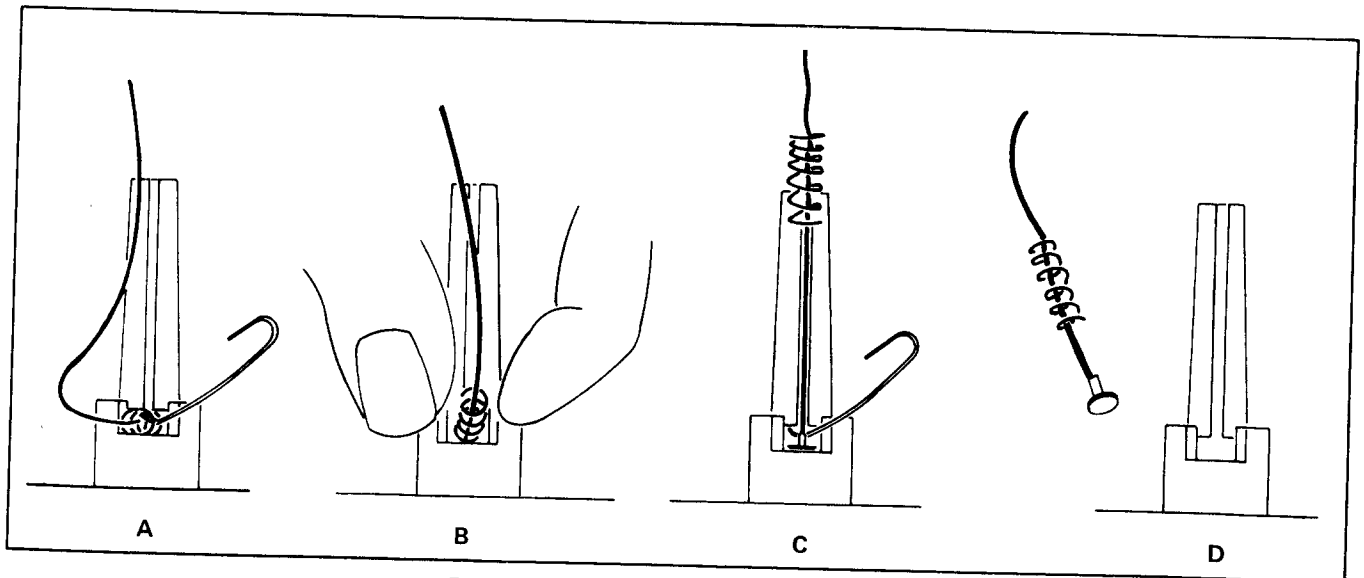

Figure 4-1. Removing the mA Input Line

3. Remove the two screws that connect the Main PCB and the Front Panel Assembly. The screws are located at the right front of the instrument.
4. Carefully slide the front panel forward until it is clear of the switches and Display Assembly. Let the Front Panel Assembly drop clear of the Display Assembly.
5. Remove the two screws connecting the Main PCB and the Display Assembly.
6. Place your fingernail under the grey tabs on the display frame and lift them free of the white screwposts on the display mounting bracket.
7. Rotate the display frame forward and down until the two hooks on the bottom of the display frame release the display mounting bracket.
8. The LCD may now be lifted free from the display mounting bracket.
9. A small length of flat, flexible material may fall out. This is the zebra strip. The zebra strip is an elastomeric strip of alternate areas of conductive and non-conductive material. When the screws are tightened to hold down the display assembly, this zebra strip provides electrical contact between the pins on the LCD and the land pattern on the Main PCB. The zebra strip is located in a channel on the display mounting bracket.
10. To replace the LCD, logically reverse this procedure.

4-17. Cleaning

CAUTION

Do not use aromatic hydrocarbons or chlorinated solvents for cleaning. These solutions will react with the plastic materials used in the instrument

CAUTION

Do not get the liquid crystal display wet. Remove the display assembly before washing the pcb and do not install it until the pcb has been fully dried.

- 4-18. Clean the front panel and case with a mild solution of detergent and water. Clean dust from the circuit board with clean, dry, low pressure air (20 psi). Contaminates can be removed from the pcb with demineralized water and a soft brush (remove the display assembly before washing the Main PCB and avoid

getting excessive amounts of water on the switches). Dry with clean, dry, low pressure air, and then bake at 50°C to 60°C (124°F to 140°F) for 24 hours.

4-19. Special Test Devices

- 4-20. There are two devices that you can make that will improve the efficiency and accuracy in performing the Calibration Procedure. The two devices are the 19Ω Test Set and the 1.9Ω Test Set. They insure good electrical contact and consistent results. Use the following data to construct them.

4-21. 19Ω TEST SET

- 4-22. The components needed are one 19 ±0.05% Ω precision resistor and one single banana connector with two terminal isolation. The Pomona connector, model number 1390-2, and the Dale Electronics, Inc., precision RS-1/4 resistor specified for 19 ±0.05% Ω, will meet the requirements for the 19Ω Test Set. See Figure 4-2 for assembly.

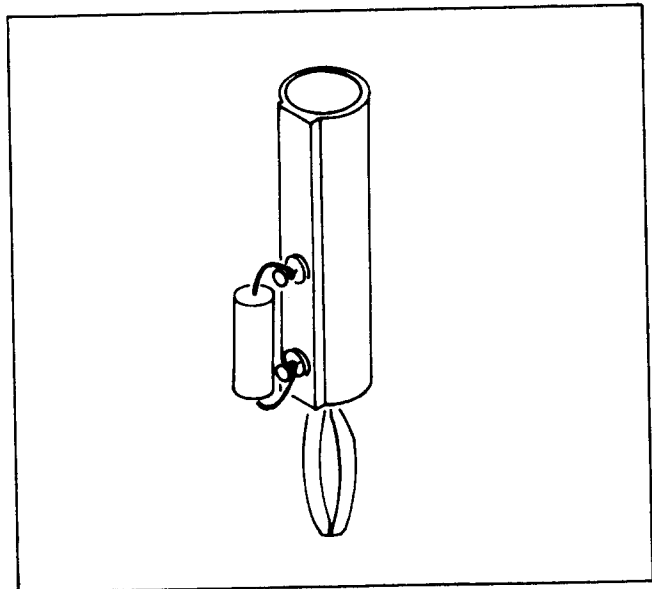

Figure 4-2. 19Ω and 1.9Ω Test Sets

4-23. 1.9Ω TEST SET

- 4-24. The components needed are on 1.9 ± 0.05% Ω precision resistor and one single banana connector with two terminal isolation. The Pomona connector, model number 1390-2, and the Dale Electronics, Inc., precision RS-1/4 resistor specified for 1.9 ±0.05% Ω will meet the requirements for the 1.9Ω Test Set. See Figure 4-2 for assembly.

4-25. PERFORMANCE TESTS

- 4-26. The performance test is used to compare the performance of your instrument with the list of

specifications given in Section 1. The performance test is recommended for incoming inspection, a preventative maintenance check, and to verify specifications. If the instrument fails any part of the performance test, calibration and/or repair is indicated.

4-27. Allow the instrument to stabilize and test it at an ambient temperature of $23 \pm 5^{\circ}\text{C}$ ($73 \pm 9^{\circ}\text{F}$). For the remainder of the performance test and the calibration procedure, your instrument will be referred to as the UUT (Unit Under Test).

4-28. Display Test

4-29. Use the following procedure to test the operation of all display digits, segments and decimal point locations.

1. On the UUT, set the POWER switch to the ON position.
2. On the UUT, select the $\text{k}\Omega$ function, 2000 $\text{k}\Omega$ range.
3. Verify that the overrange indication (1) illuminates.
4. Select the V function.
5. Verify that the LCD displays 000.
6. Connect the Lo Ohms Calibration Lead between the V/ $\text{k}\Omega$ /S and COMMON input terminals.
7. Select each range in sequence starting with the 200 mV range. Verify that the decimal point location agrees with Table 4-2.
8. Remove the Lo Ohms Calibration Lead.
9. Connect the HI output of the Multimeter Calibrator to the V/ $\text{k}\Omega$ /S input of the UUT. Connect the LO output of the Multimeter Calibrator to the COMMON input terminal of the UUT.
10. On the UUT, select the DC V function, 20V range.
11. Program the Multimeter Calibrator for an output of -18.88V . This checks each segment of every digit in the display.

Table 4-2. Decimal Point Locations

RANGE	LCD DISPLAY
200 mV	00.0
2V	.000
20V	0.00
200V	00.0
1000V	000
no reading (10A/20 M Ω)	0.00

4-30. Resistance/Conductance Test

4-31. Use the following procedure to verify the operation and performance of the resistance and conductance ranges.

1. Short together the COMMON and V/ $\text{k}\Omega$ /S input terminals.
2. On the UUT, select the $\text{k}\Omega$ function, 200 Ω range.
3. Verify that the display reading is 00.0 to 00.2.
4. Remove the Shorting Unit.
5. On the UUT, select the conductance function, 200 nS range.
6. Verify that the display reading is between 00.0 and 00.3.
7. Connect the HI output of the Multimeter Calibrator to the V/ $\text{k}\Omega$ /S input terminal of the UUT. Connect the LO output of the Multimeter Calibrator to the COMMON input terminal of the UUT.
8. Verify the remainder of the ranges by using Table 4-3 and the following procedure. For each step of Table 4-3:
 - a. On the UUT, select the range indicated under the Range column.
 - b. Program the Multimeter Calibrator for the value listed under the MC output column.
 - c. Verify that the display reading on the UUT falls within the values under the Display Reading column.

Table 4-3. Resistance/Conductance Test

STEP	RANGE	MC OUTPUT	DISPLAY READING
1	200 Ω	100 Ω	99.7 to 100.3
2	2 k Ω	1 k Ω	997 to 1003
3	20 k Ω	10 k Ω	9.97 to 10.03
4	200 k Ω	100 k Ω	99.7 to 100.3
5	2000 k Ω	1 M Ω	994 to 1006
6	20 M Ω	10 M Ω	9.94 to 10.06
7	2 mS	1 k Ω	0.997 to 1.003
8	20 μ S	100 k Ω	9.97 to 10.03
9	200 nS	10 M Ω	98.0 to 102.0

4-32. LO Range Ω Test - 8012A Only

4-33. Use the following procedure to verify the operation and accuracy of the Low Ohms function of your 8012A.

1. On the UUT, select the LO RANGE Ω function, 2 Ω range.
2. Connect the LO Ohms Calibration Lead between the LO RANGE Ω and COMMON input terminals.
3. Adjust the ZERO control for an LCD display of all zeros.
4. Remove the LO Ohms Calibration Lead from the COMMON input terminal, plug the 1.9 Ω Test Set into the COMMON input terminal, and connect Lo Ohms Calibration Lead to the 1.9 Ω Test Set.
5. Verify the LCD display is between 1.879 and 1.921.
6. On the UUT, select the 20 Ω range.
7. Replace the 1.9 Ω Test Set with the 19 Ω Test Set.
8. Verify that the LCD display is between 18.88 and 19.12.

4-34. DC Voltage Test

4-35. Use the following procedure to verify operation and accuracy of the DC Voltage function of the UUT.

1. Connect the HI output of the Multimeter Calibrator to the V/k Ω /S input terminal of the

UUT. Connect the LO output of the Multimeter Calibrator to the COMMON input of the UUT.

2. On the UUT, select the DC V function.
3. Use Table 4-4 and the following procedure:
 - a. On the UUT select the range listed under the Range column.
 - b. Program the Multimeter Calibrator for the value listed under the MC output column.
 - c. Verify that the LCD display is within the values listed under the Display column.

Table 4-4. DC Voltage Test

STEP	RANGE	MC OUTPUT	DISPLAY
1	20 mV	+190.0 mV	+189.7 to +190.3
2	2V	+1.900V	+1.897 to +1.903
3	20V	+19.00V	+18.97 to +19.03
4	20V	-19.00V	-18.97 to -19.03
5	200V	+190.0V	+189.7 to +190.3
6	1000V	+1000V	+998 to +1002

4-52. RMS Converter Offset Adjustment

4-37. Use the following procedure to verify the proper offset of the RMS converter.

1. On the UUT, select the AC V function, any range.
2. Connect the Lo Ohms Calibration Lead between the V/k Ω /S and COMMON terminals.
3. On the UUT, measure and record the voltage level on TP1 with the DMM.
4. Verify that this level is between ± 20 mV.
5. Measure the voltage level on TP2.
6. Verify that the voltage level on TP2 is within 1 mV of the level recorded from TP1.

4-38. AC Voltage Test

4-39. Use the following procedure to verify the accuracy and operation of the AC Voltage function.

1. Connect the HI output of the Multimeter Calibrator to the V/k Ω /S input terminal of the

UUT. Connect the LO output of the Multimeter Calibrator to the COMMON input terminal of the UUT.

2. On the UUT, select the AC V function.
3. Use Table 4-5 and the following procedure:
 - a. On the UUT select the range indicated in the Range column.
 - b. Program the Multimeter Calibrator for the level and frequency output listed under the MC Output column.
 - c. Verify that the LCD display is within the values listed under the Display Reading.

Table 4-5. AC Voltage Test

STEP	RANGE	MC OUTPUT		DISPLAY READING
		LEVEL	FREQ	
1	200 mV	190.0 mV	100 Hz	188.8 to 191.2
2	200 mV	10.0 mV	100 Hz	9.8 to 10.2
3	2V	1.900V	100 Hz	1.888 to 1.912
4	20V	19.00V	100 Hz	18.88 to 19.12
5	200V	190.0V	100 Hz	188.8 to 191.2
6	750V	750V	100 Hz	744 to 756
7	750V	250V	1 kHz	247 to 253
8	20V	1.00V	10 kHz	0.97 to 1.03
9	20V	19.00V	10 kHz	18.79 to 19.21
10	200V	110.0V	10 kHz	108.7 to 111.3
11	20V	19.00V	50 kHz	18.03 to 19.97

4-40. DC Current Test

4-41. Use the following procedure to verify operation and accuracy of the DC Current function.

1. Connect the HI output of the Multimeter Calibrator to the mA input terminal of the UUT. Connect the LO output of the Multimeter Calibrator to the COMMON input terminal of the UUT.
2. On the UUT, select the DC mA/A function.
3. Use Table 4-6 and the following procedure. For each step in Table 4-6:
 - a. On the UUT, select the range listed under the Range column.

b. Program the Multimeter Calibrator for the output listed under the MC Output column.

c. Verify that the LCD display is within the values listed under the Display Reading column.

Table 4-6. DC mA Test

STEP	RANGE	MC OUTPUT	DISPLAY READINGS
1	200 μ A	190.0 μ A	189.3 to 190.7
2	2 mA	1.900 mA	1.893 to 1.907
3	20 mA	19.00 mA	18.93 to 19.07
4	200 mA	190.0 mA	189.3 to 190.7
5	2000 mA	1900 mA	1893 to 1907

4-42. AC Current Test

4-43. Use the following procedure to verify operation and accuracy of the AC Current function.

1. Connect the HI output of the Multimeter Calibrator to the mA input terminal of the UUT. Connect the LO output of the Multimeter Calibrator to the COMMON input terminal of the UUT.
2. On the UUT, select the AC mA/A function, 200 μ A range.
3. Program the Multimeter Calibrator for an output level of 190.0 μ A at a frequency 1 kHz.
4. Verify that the LCD display is within the values: 187.9 to 192.1 μ A.

4-44. 10A Current Test - 8010A Only

4-45. Use the following procedure to verify the operation and accuracy of the 10A function of your 8010A.

1. Connect the HI output of the Multimeter Calibrator to the 10A input terminal on the UUT. Connect the LO output of the Multimeter Calibrator to the COMMON input terminal on the UUT.
2. On the UUT, select the DC mA/A function, 10A range.
3. Program the Multimeter Calibrator for an output of 1900 mA DC.
4. Verify that the LCD display is between these values: 1.88 to 1.92 A.

4-46. CALIBRATION PROCEDURE

4-47. The calibration procedure should be used any time your instrument has been repaired or fails to pass the Performance Test. The Calibration Procedure has four sections: The Turn-On Check - verifies proper power supply voltages, DC Calibration Adjustment - sets up the DC voltage/DC Current/Resistance/Conductance functions, AC Calibration Adjustments - sets up all AC functions, and the Low Ohms Calibration Adjustment - sets up the Low Ohms function for the 8012A. Perform the Calibration Access Procedure before starting any section of the Calibration Procedure.

NOTE

Since the components are on the bottom side of the pcb's, it will be necessary to turn the instrument upside down to gain access to the calibration adjustments. This inverts the display. If you have trouble reading the inverted display, there are two alternatives. First, you can stand at the side of your instrument facing the front of the instrument. Lean forward and the display will appear to be right-side-up. If this is unsatisfactory, turn the outer cover on its side with the handle perpendicular to the cover. Place a weight on the bottom leg of the handle. Connect the power cord to the power receptacle on the Main PCB and carefully slide the Main PCB about halfway back into the outer case.

4-48. Power Supply Check

4-49. Use the following procedure to verify the power supply voltages of your instrument.

1. Apply line power to the UUT. Insure that this power is at the correct voltage and frequency for your version of the instrument.
2. Place the POWER switch in the ON position.

3. On the UUT, select the DC V function, 200V range.
4. Verify that the LCD reads $00.0 \pm 0.1V$.
5. With the DMM, check the power supply voltages listed in Table 4-7.

4-50. DC Calibration Adjustment

4-51. Use the following procedure to set up the DC voltage/DC current/Resistance/Conductance functions.

1. On the UUT, select the DC V function, 2V range.
2. Connect the HI output terminal of the Multimeter Calibrator to the V/kΩ/S input terminal of the UUT using the red calibration lead. Connect the LO output terminal of the MC to the COMMON input terminal of the UUT using the black calibration lead.
3. Program the Multimeter Calibrator for a DC output of 1.888V. (This voltage is chosen so that all segments of all digits are checked.)
4. On the UUT, adjust R4 (DC CAL) for a display of exactly 1.888 on the LCD.
5. Reverse the input leads to the UUT.
6. Verify that the LCD reading is between -1.887 to -1.889.
7. If necessary, adjust R6 until both readings are within 1 digit of 1.888V.

4-52. RMS Converter Offset Adjustment

4-53. Use the following procedure to adjust the offset of the RMS converter.

Table 4-7. Power Supply Voltages

TEST POINT	VOLTAGE FUNCTION	VOLTAGE LEVEL SHOULD READ BETWEEN:		
		FOR 115V, 60 Hz VERSION	FOR 100V, 50-60 Hz VERSION	FOR 230V, 50 Hz VERSION
TP5		$-2.1 \pm 0.4V$	$-2.1 \pm 0.4V$	$-2.1 \pm 0.4V$
TP7	-VSS	$-6.5 \pm 1V$	$-4.7 \pm 1V$	$-6.5 \pm 1V$
TP8	-VA	$-15 \pm 1V$	$-11 \pm 1V$	$-15 \pm 1V$
TP9	+VDD	$+2.9 \pm 0.3V$	$+2.9 \pm 0.3V$	$+2.9 \pm 0.3V$
TP10	+VA	$+15 \pm 1V$	$+11 \pm 1V$	$+15 \pm 1V$

1. On the UUT, select the AC V function, any range.
2. Connect the Lo Ohms Calibration Lead between the V/k Ω /S and COMMON terminals.
3. With the DMM, measure and record the voltage level on TP1.
4. Verify that the level is between ± 20 mV.
5. Connect the DMM to TP2.
6. Adjust R7 on the RMS hybrid network so that the voltage level on TP2 is within 0.5 mV of the level recorded on TP1.

4-54. AC Calibration Adjustment

4-55. The following procedure sets up the circuitry for the AC functions. There are four interacting adjustments: two potentiometers for setting low and high levels at low frequencies and two variable capacitors for setting high levels at high frequency.

1. On the UUT, select AC V, 2V range.
2. Program the Multimeter Calibrator for an output of 1.900V rms at a frequency of 100 Hz.
3. Connect the HI output of the Multimeter Calibrator to the V/k Ω /S input of the UUT using the red calibration lead. Connect the LO output of the Multimeter Calibrator to the COMMON input of the UUT using the black calibration lead.
4. Set R21 to the middle of its adjustment range.
5. Adjust R19 (AC HI) for a display of exactly 1.900V.
6. Program the Multimeter Calibrator for an output of 190.0 mV at 100 Hz.
7. On the UUT, select the 2V range.
8. Adjust R21 (AC LO) for a display of exactly .190.
9. The adjustments of R19 and R21 are interacting. Repeat steps 1 through 7 of this procedure until both readings are within 1 count of the designated values.
10. On the UUT, select a range of 20V.
11. Program the Multimeter Calibrator for an output of 19.00V at a frequency of 10 kHz.

12. Adjust C1 for a display of exactly 19.00V.
13. On the UUT, select a range of 200V.
14. Program the Multimeter Calibrator for an output of 110.0V at a frequency of 10 kHz.
15. Adjust C4 for a display of exactly 110.0V.
16. Check all four of the AC calibration adjustment levels, make adjustments as necessary.

4-56. Lo Range Ω Calibration Adjustment

4-57. Use the following procedure to adjust the LO RANGE Ω circuitry.

1. On the UUT, select the LO RANGE Ω function, 20 Ω range.
2. Connect the Lo Ohms Calibration Lead between the COMMON and LO RANGE Ω input terminals.
3. Adjust the ZERO controls until the LCD displays all zeros.
4. Remove the Lo Ohms Calibration Lead from the COMMON terminal, plug the 19 Ω Test Set into the COMMON terminal and plug the Lo Ohms Calibration Lead into the 19 Ω Test Set.
5. On the UUT, Low Ohms PCB, adjust R57 for an LCD display of exactly 19.00 Ω .
6. Replace the 19 Ω Test Set with the 1.9 Ω Test Set.
7. On the UUT, select the 2 Ω range.
8. Verify that the display is between 1.879 and 1.921.

4-58. TROUBLESHOOTING

CAUTION

Static discharge can damage MOS components contained in your instrument.

4-59. When troubleshooting or repairing your meter, use the following precautions to prevent damage from static discharge:

1. Never remove, install or otherwise connect or disconnect components without first setting the POWER switch to OFF.

2. Perform all repairs at a static-free work station.
3. Do not handle IC's or pcb's by their connectors.
4. Use static ground straps to discharge repair personnel.
5. Use conductive foam to store replacement or removed IC's.
6. Remove all plastic, vinyl and styrofoam products from the work area.
7. Use a grounded soldering iron.

4-60. A troubleshooting guide for your instrument is given in Table 4-8. To properly use the guide complete the performance test given earlier in this section and note any discrepancies. Then locate the heading of the procedure in question in the Test and Symptom column (Table 4-8). Under that heading isolate the symptom that approximates the observed malfunction. Possible causes are listed to the right of the selected symptom. Details necessary to isolate a particular cause can be derived from the theory of operation in Section 3 and the schematic diagram in Section 8. Table 4-9 lists the test points in the instrument.

Table 4-8. Troubleshooting Guide

TEST AND SYMPTOM	POSSIBLE CAUSE
INITIAL PROCEDURE	
Display blank	Power supply, power switch, U3.
DISPLAY TEST	
One or more segments will not light through entire test.	Display interconnection, display, or A/D Converter U3.
Decade inoperative or one or more segments always lit.	U3.
Improper decimal point indication.	Range switches, U5, U6, or display. (Check signals at U6 to isolate.)
Minus sign improperly displayed.	U3.
Display lit but does not respond to changes in input.	Reference U7, crystal U1, A/D Converter U3, Touch and Hold signal line grounded, Q3, Q4.
RESISTANCE/CONDUCTANCE TEST	
Displayed reading is out of tolerance on at least one but not all ranges.	Range resistor U1 or R3.
Readings are noisy on all ranges.	Thermistor RT1.
Readings are out of tolerance on high ohms.	RV1, RV2, RV3 overheated from severe overload.
Residual reading with test leads open.	PCB is contaminated. (See cleaning procedure Section 4.)
DC VOLTAGE TEST	
Display reading is out of tolerance on 200 mV or 2V range.	Out of calibration (DC), Vref (U7, in error, R4, U3.)
Readings are out of tolerance on all ranges except 200 mV and 2V.	Range resistor U1.
AC VOLTAGE TEST	
Displayed reading is out of tolerance on 200 mV range.	Out of calibration (AC), AC converter defective.
Readings out of tolerance on all ranges except 200 mV.	Range resistor U1, C1, C4 out of calibration.
DC CURRENT TEST	
Input does not affect display.	Fuse F1, F2, CR1, U4.
Displayed reading is out of tolerance on one or more ranges.	R7, R8, R9, U2, R10.

Table 4-9. Test Points

TEST POINT	SIGNAL/CONNECTION	TEST POINT	SIGNAL/CONNECTION
TP1	RMS Converter	TP8	-VA
TP2	RMS Converter Input	TP9	+VDD
TP3	Compensation Network Input	TP10	+VA
TP4	A/D Converter HI Input	TP11	Range control input to A/D Converter
TP5	Digital Reference for A/D Converter Range	TP12	DC Reference Voltage
TP6	COMMON	TP13	Used with the -01 Option (Battery Charging Circuit)
TP7	-VSS	TP14	Used with the -01 Option (Battery Charging Circuit)

Section 5

List of Replaceable Parts

TABLE OF CONTENTS

TITLE	TABLE	PAGE	FIGURE	PAGE
Final Assembly	5-1	5-3	5-1	5-3
A1 Main PCB Assembly	5-2	5-4	5-2	5-7
A2 Low Ohms PCB Assembly	5-3	5-8	5-3	5-8

5-1. INTRODUCTION

5-2. This section contains an illustrated parts breakdown of the instrument. Components are listed alpha-numerically by assembly. Electrical components are listed by reference designation and mechanical components are listed by item number. Each listed part is shown in an accompanying illustration.

5-3. Parts lists include the following information:

1. Reference Designation or Item Number.
2. Description of each part.
3. FLUKE Stock Number.
4. Federal Supply Code for Manufacturers. (See Appendix A for Code-to-Name list.)
5. Manufacturer's Part Number or Type.
6. Total Quantity per assembly or component.
7. Recommended Quantity: This entry indicates the recommended number of spare parts necessary to support one to five instruments for a period of two years. This list presumes an availability of common electronic parts at the maintenance site. For maintenance for one year or more at an isolated site, it is recommended that at least one of each assembly in the instrument be stocked. In the case of optional subassemblies, plug-ins, etc. that are

not always part of the instrument, or are deviations from the basic instrument model, the REC QTY column lists the recommended quantity of the item in that particular assembly.

8. The Use Code: This entry indicates a note number. The corresponding note will be at the end of that table.

5-4. HOW TO OBTAIN PARTS

5-5. Components may be ordered from the nearest Fluke authorized service center listed at the rear of this manual. To ensure prompt and efficient handling of your order, include the following information.

1. Quantity.
2. FLUKE Stock Number.
3. Description.
4. Reference Designation or Item Number.
5. Printed Circuit Board Part Number.
6. Instrument Model Number and the Rev. letter inked on the pcb assembly.

CAUTION

Indicated devices are subject to damage by static discharge.

Table 5-1. Final Assembly

ITEM NO.	DESCRIPTION	FLUKE STOCK NO.	MFG SPLY CODE	MFG PART NO. OR TYPE	TOT QTY	REC QTY	USE CDE
8010A/8012A FINAL ASSEMBLY FIGURE 5-1							
A1	MAIN PCB ASSEMBLY	ORDER	NEXT	HIGHER ASSY	1		
A2	LOW OHMS PCB ASSEMBLY	ORDER	NEXT	HIGHER ASSEMBLY	1		
H1	SCREW,PH,6-32 X 3/8	334458	89536	334458	1		
H2	SCREW,PH,6-20 X 3/8	228266	89536	228266	2		
H3	WASHER,FLAT	340505	89536	340505	1		
H4	TEST LEADS (NOT SHOWN)	343657	28480	21058	1		
MP1	DECAL,HANDLE,DISC	478248	89536	478248	1		
MP2	CASE,MOLDED	478008	89536	478008	1		
MP3	HANDLE, MOLDED	330092	89536	330092	1		
MP4	PAD,FOOT (NOT SHOWN)	338632	89536	338632	1		
MP5	DECAL,FRONT PANEL	ORDER	FOR	CORRECT MODEL	1		
	MODEL 8010A	473272	89536	473272	1		
	MODEL 8012A	477471	89536	477471	1		
MP6	DECAL,SPECIFICATION (NOT SHOWN)	473280	89536	473280	1		
MP7	KNOB, CONTROL, ZERO	479626	89536	479626	1		
P1	SOCKET, 7 POS.	484030	00779	1583773-4	1		
W1	LINE CORD(NOT SHOWN)	ORDER	FOR	CORRECT SOURCE	1		
	100V,115V SOURCE	343723	89536	343823	1		
	230V SOURCE	343780	89536	343780	1		

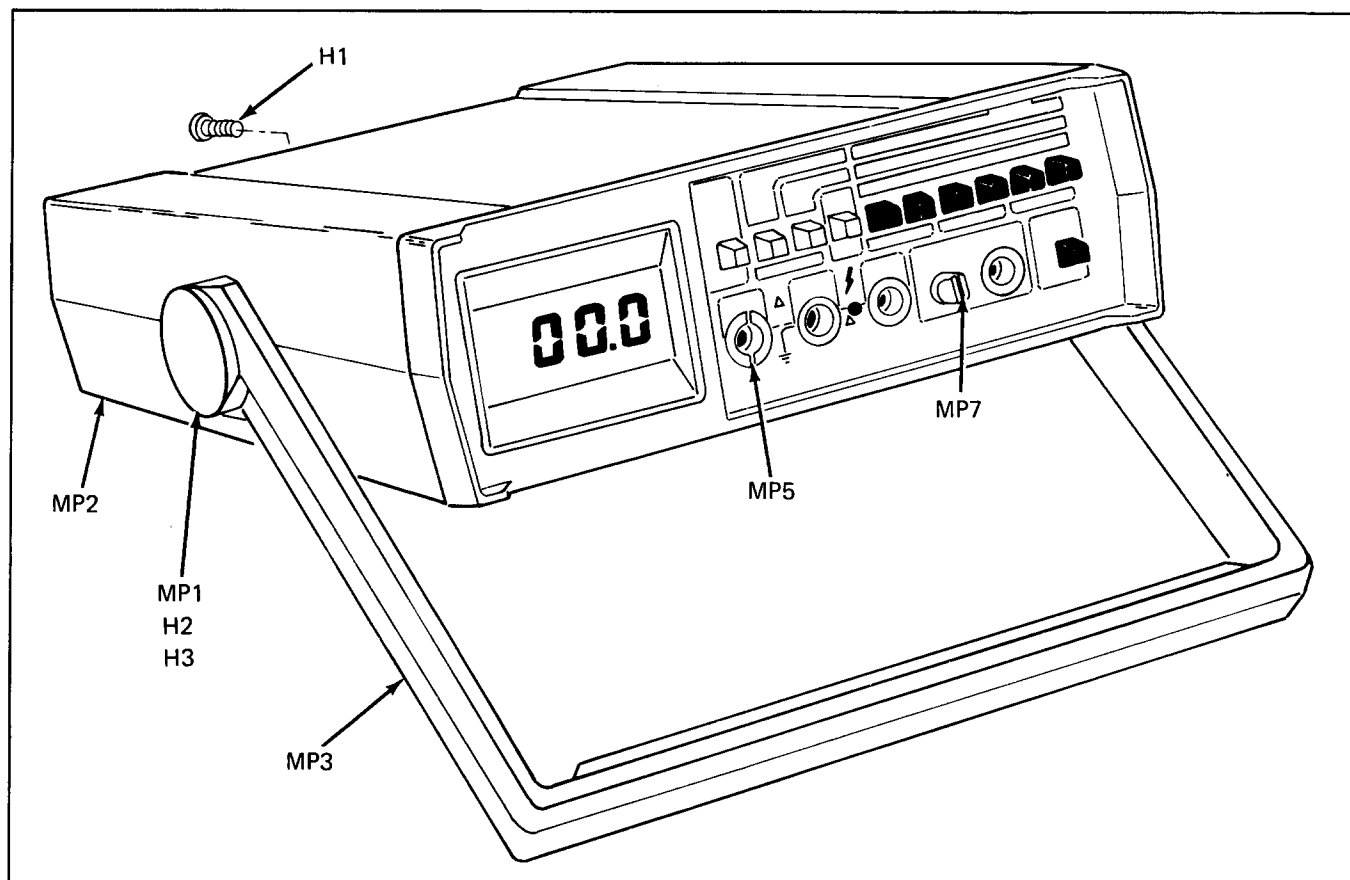

Figure 5-1. Final Assembly

Table 5-2. A1 Main PCB Assembly

ITEM NO.	DESCRIPTION	FLUKE STOCK NO.	MFG SPLY CODE	MFG PART NO. OR TYPE	TOT QTY	REC QTY	USE CDE
A1	MAIN PCB ASSEMBLY	ORDER	NEXT	HIGHER ASSEMBLY			
	FIGURE 5-2	418780	12040	LF351N	1	1	
AR1	IC,LIN OP-AMP	218206	72982	530-000	2	1	
C1	CAP,VAR,1.5PF-0.25PF,200V	148478	72136	DM15F151J	2		
C2	CAP,MICA,150PF +/-5%,500V						
C3	CAP,MICA,120PF +/-5%,500V	148486	72136	DM15F121J	1		
C4	CAP,VAR,1.5PF-0.25PF,200V	218206	72982	530-000	REF		
C5	CAP,MICA,2200PF +/-5%,500V	148346	72136	DM19F222J	REF		
C6	CAP,MYLAR,0.047UF +/-10%,250V	162008	73445	C280AMAE47K	1		
C7	CAP,MICA,150PF +/-5%,500V	148478	72136	DM15F151J	REF		
C8	CAP,TA,10UF +/-20%,15V	193623	56289	196D106X0015KA1	3		
C9	CAP,POLY,0.622UF +/-10%,100V	448183	03797	0.22/10/1000-7	1		
C10	CAP,ELECT,22UF -10/+75%,16V	436840	89536	436840	1	1	
C11	CAP,MYLAR,0.047UF +/-10%,250V	446773	89536	446773	2		
C12	CAP,MICA,470PF +/-5%,500V	148429	72136	DM19E471J	1		
C13	CAP,MYLAR,0.047UF +/-10%,250V	446773	89536	446773	REF		
C14	CAP,POLY,0.1UF +/-10%,2500V	446781	89536	446781	1		
C15	CAP,POLY,0.22UF +/-10%,100V	436113	73445	C280MAH1A220K	1		
C16	CAP,CER,0.01UF +/-20%,100V	149153	56289	C023B101F103M	2		
C17	CAP,CER,500PF +/-10%,500V	105692	56289	C067B102E501K	1		
C18	CAP,TA,2.2UF +/-20%,20V	161927	56289	196D225X0020HA1	1		
C19	CAP,TA,10UF +/-20%,15V	193623	56289	196D106X0015	REF		
C30	CAP,ELECT,220UF -10/+75%,25V	484071	89536	484071	2	1	
C31	CAP,ELECT,220UF -10/+75%,25V	484071	89536	484071	REF		
C32	CAP,ELECT,220UF -10/+75%,16V	435990	89536	435990	1	1	
C33	CAP,TA,10UF +/-20%,15V	193623	56289	196D106X0015	REF		
C34	CAP,CER,0.01UF +/-20%,100V	149153	56289	C023B101F103M	REF		
CR1	DIODE,SI,RECT. 2A,50V	347559	05277	IN5400	1		
CR2	DIODE,SI,LO-CAP,LO-LEAK	348177	07263	FD7223	2	1	
CR3	DIODE,SI,LO-CAP,LO-LEAK	348177	07263	FD7223	REF		
CR9	DIODE,SI,RECT. 1A,100V	343491	01295	IN4002	3		
CR10	DIODE,SI,RECT. 1A,100V	343491	01295	IN4002	REF		
CR11	DIODE,SI,RECT. 1A,100V	343491	01295	IN4002	REF		
DS1	LIQUID CRYSTAL DISPLAY (LCD)	453100	89536	453100	1		
F1	FUSE,FAST-BLO,2A,250V						
	AMERICAN SIZE, 1 X 1/4	376582	71400	AGX2	1	5	
	METRIC SIZE, 20MM X 5MM	460972	89536	460972	1	5	
F2	FUSE,FIBRE,3A,600V	475004	71400	BBS-3	1	5	
H1	PUSH ROD	479634	89536	479634	1		
H2	GROMMET,POLY	435974	06915	PG-S-2	1	1	
H3	SCREW,RHP,4-40 X 1/4	256156	89536	256156	4		
H4	SCREW,RHP,#5 X 5/16	494641	89536	494641	2		
H5	RIVET	233932	83058	MS49338-2	6		
H6	SCREW,RHP,6-32 X 3/16	114942	89536	114942	2		
H7	INSULATOR	495044	89536	495044	1		
H8	SCREW	114942	89536	114942	1		
H9	SPACER,STANDOFF	347526	89536	347526	1		
H10	GROMMET	493015	89536	493015	REF		
JA1	RECEPTACLE,AC	471029	89536	471029	1		
MP1	PANEL,FRONT	ORDER	NEXT	HIGHER ASSEMBLY	1		

Table 5-2. A1 Main PCB Assembly (cont)

ITEM NO.	DESCRIPTION	FLUKE STOCK NO.	MFG SPLY CODE	MFG PART NO. OR TYPE	TOT QTY	REC QTY	USE CDE
MP2	SHIELD, TOP	471037	89536	471037	1		
MP3	SHIELD, BOTTOM	471045	89536	471045	1		
MP4	BRACKET, LCD	471730	89536	471730	1		
MP5	BEZEL, LCD	479642	89536	479642	1		
MP6	BUTTON, SWITCH, GREEN	445197	89536	445197	1		
MP7	BUTTON (S4 THRU S7)	425900	89536	425900	2		
MP8	BUTTON (S8 THRU S13)	426759	89536	426759	6		
MP9	SPRING, COMP, SS	422824	84830	LC-0226-3	1	1	
Q1	XSTR, SI, NPN	483859	89536	483859	4	1	
Q2	XSTR, SI, NPN	483859	89536	483859	REF		
Q3	XSTR, SI, NPN	483859	89536	483859	REF		
Q4	XSTR, SI, PNP	195974	89536	195974	2	1	
Q5	XSTR, SI, PNP	195974	89536	195974	REF		
Q9	XSTR, SI, NPN	483859	89536	483859	REF		
R1	RES, COMP, 100K +/-10%, 1W	109397	01121	GB1031	1		
R2	RES, COMP, 1K +/-10%, 2W	474080	01121	HB1021	1		
R3	RES, MF, 1K +/-0.1%, 1/8W	474445	91637	CMF551001B	1		
R4	RES, VAR, CRMT, 200 +/-10%, 1/2W	474973	89536	474973	1	1	
R5	RES, DEP CAR, 1M +/-5%, 1/4W	348987	80031	CR251-4-5P1MT	2		
R6	RES, DEP. CAR, 100 +/-5%, 1/4W	348771	80031	CR251-4-5P100ET	1		
R7	RES, MF, 900 +/-0.1%, 1/8W	461988	89236	461988	1		
R8	RES, MF, 90.0 +/-0.1%, 1/8W	461970	89536	461970	1		
R9	RES, WW, 9.000 +/-0.15%, 3W	461962	89536	461962	1		
R10	RES, FXD, 0.01 +/-0.25%, 1W	461780	80031	461780	1		
R11	RES, COMP, 22M +/-10%, 1/2W	108233	01121	HB2251	2		
R12	RES, COMP, 22M +/-5%, 1/4W	221986	01121	CB2255	1		
R13	RES, DEP CAR, 1 +/-5%, 1/4W	357665	80031	CR251-4-5PIET	1		
R14	RES, COMP, 100K +/-5%, 2W	285056	01121	HB1045	1		
R15	RES, DEP CAR, 15 +/-5%, 1/4W	348755	80031	CR251-4-5PI5ET	1		
R16	RES, COMP, 1M +/-10%, 1W	109793	01121	GB1051	1		
R17	RES, DEP CAR, 220K +/-5%, 1/4W	348953	80031	CR251-4-5P220KT	1		
R18	RES, DEP CAR, 1K +/-5%, 1/4W	343426	80034	CR251-4-5PIKT	1		
R19	RES, VAR, CRMT, 5K +/-10%, 1/2W	478883	89536	478883	1	1	
R20	RES, DEP CAR, 2.2M +/-5%, 1/4W	342659	80031	CR251-4-5P2M2T	1		
R21	RES, VAR, 1M +/-10%, 1/2W	485052	89536	485052	1	1	
R22	RES, DEP CAR 470K +/-5%, 1/4W	342634	80031	CR251-4-5P470KT	1		
R23	RES, DEP CAR, 1M +/-5%, 1/4W	348987	80031	CR251-4-5P1MT	REF		
R30	RES, DEP CAR, 4.7K +/-5%, 1/4W	348821	80031	CR251-4-5P4K7T	1		
R31	RES, DEP CAR, 100K +/-5%, 1/4W	348920	80031	CR251-4-5P100KT	1		
R32	RES, COMP, 22M +/-10%, 1/2W	108233	01121	HB2251	REF		
RT1	RES, CL, 1K +/-40%, 2W, 25 DEG C	446849	50157	180010200	1		
RV1	VARIATOR, 430V +/-10%	447672	09214	V430MA7B	3	1	
RV2	VARIATOR, 430V +/-10%	447672	09214	V430MA7B	REF		
RV3	VARIATOR, 430V +/-10%	447672	09214	V430MA7B	REF		
S1	SWITCH, POWER	473736	89536	473736	1		
S3	SWITCH SLIDE	453365	34828	G1-116-0001-G20-52	2	1	
S20	SWITCH, ASSY. (S4 THRU S13)	473322	89536	473322	1		
T1	TRANSFORMER, POWER	ORDER	FOR	CORRECT SOURCE			
	100V, 115V SOURCE	461509	89536	461509	1		
	230V SOURCE	461723	89536	461723	1		

1

3

Table 5-2. A1 Main PCB Assembly (cont)

ITEM NO.	DESCRIPTION	FLUKE STOCK NO.	MFG SPLY CODE	MFG PART NO. OR TYPE	TOT QTY	REC QTY	USE CDE
U1	RES, NETWORK, 10.0M, 101K, 11.1K	461483	89536	461483	1	1	
U2	RES, NETWORK, .100, .900	461491	89536	461491	1	1	
U3 ⊗	IC, C-MOS, A/D CONVERTER	429100	89536	429100	1	1	
U4	IC, FW. RECT. BRIDGE, 50V-1000V, 1A	418582	83003	VM08	1	1	
U5	RES, NETWORK, 25 DEG.C, +/-5%, 1/8W	474999	89536	474999	1	1	
U6	IC, COS/MOS, QUAD XOR GATE	355222	89536	355222	1	1	
U7	IC, LIN, 2.5V BAND-GAP REF	472845	04713	MC1403V	1	1	
U8	HYBRID RMS CONVERTER	480897	89536	480897	1	1	
VR2	DIODE, ZENER, 4.3V	180455	07910	IN749A	1	1	
W1	CONNECTOR, ELASTOMERIC	453092	18565	22989	1		
W10	CONNECTOR, ELASTOMERIC	453092	18565	22989		REF	
XF1	FUSE HOLDER ASSEMBLY	ORDER	FOR	CORRECT SOURCE	1		
	100V, 115V SOURCE	487967	89536	487967	1		
	230V SOURCE	487959	89536	487959	1		
XU3	SOCKET, IC, 40 PIN	429282	09922	DILB40P-108	1		
Y1	CRYSTAL	ORDER	FOR	CORRECT LINE FREQ.	1		
	60HZ (3.840MHZ) LINE FREQ.	447615	89536	447615	1		
	50HZ (3.200MHZ) LINE FREQ.	460550	89536	460550	1		
Y2	CRYSTAL, 60HZ, 3.89MHZ	447615	89536	483610	1		
Y3	CRYSTAL, 50HZ, 3.200MHZ	460550	89536	460550	1		

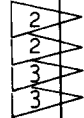

1 THIS PART USED ON THE 8010A ONLY.

2 USED ON 115V, 60HZ AND 230V, 50HZ MODELS

3 USED ON 100V, 50HZ OR 60HZ, SELECTABLE, MODELS

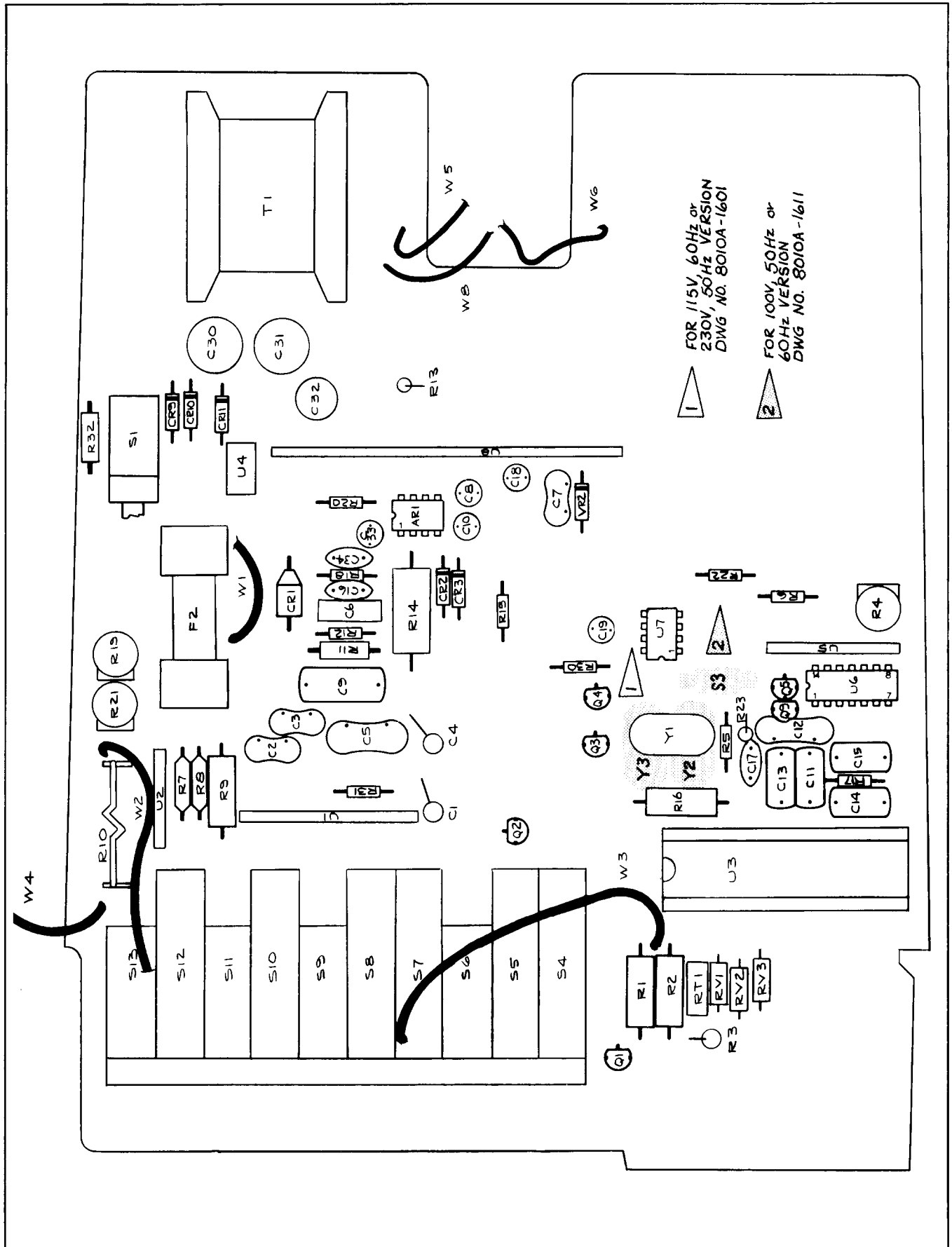

Figure 5-2. A1 Main PCB Assembly

Table 5-3. A2 Low Ohms PCB Assembly

ITEM NO.	DESCRIPTION	FLUKE STOCK NO.	MFG SPLY CODE	MFG PART NO. OR TYPE	TOT QTY	REC QTY	USE CDE
A2	LOW OHMS PCB ASSY	ORDER	NEXT	HIGHER ASSY			
A3	FIGURE 5-3 (8012A-4101)						
C50	CAP, CER, 300PF +/-10%, 500V	105734	71590	BB60301KW7W	1		
C51	CAP, CER, 0.01 UF +/-20%, 100V	149153	56282	C023B101F103M	1		
CR50	DIODE, RECT, 1000V, 1.5A	296236	05277	IN5054	1	1	
CR51	DIODE, HI-SPEED SW	203323	07910	1N4448	2	1	
CR52	DIODE, HI-SPEED SW	203323	07910	1N4448	REF		
H1	GROMMET	493601	89536	493601	1		
MP1	SPACER, STANDOFF	376228	89536	376228	3		
MP2	ROD, ACTUATOR	479626	89536	479626	1		
Q50	XSTR, SI, NPN, HI-VOLT, T0-92	370684	04713	MPS A42	1	1	
Q51	XSTR, SI, NPN, #1V	381731	04713	MPS V10	2	1	
Q52	XSTR, SI, NPN, #1V	381731	04713	MPS V10	REF		
R50	RES, COMP, 1.5M +/-5%, 1/4W	182857	01121	CB1555	1		
R51	RES, COMP, 39K +/-10%, 2W	109983	01121	HB3931	2		
R52	RES, COMP, 39K +/-10%, 2W	109983	01121	HB3931	REF		
R53	RES, COMP, 6.8K +/-5%, 1/4W	148098	01121	CB6825	1		
R54	RES, DEP CAR, 20K +/-5%, 1/4W	441477	80031	CR251-4-5P20KT	2		
R55	RES, DEP CAR, 20K +/-5%, 1/4W	441477	80031	CR251-4-5P20KT	REF		
R56	RES, MF, 113 +/-0.1%, 1/8W	484238	91637	CMF551130B	1		
R57	RES, VAR, CRMT, 20 +/-10%, 1/2W	285114	89536	285114	1	1	
R58	RES, VAR, 50K +/-20%, 1/2W	484089	01121	70M1G232K503M	1	1	
R59	RES, HI-VOLT, 100K +/-1%, 7W	484097	89536	484097	1		
R60	RES, MF, 1M +/-1%, 1/8W	268797	91637	CMF551004F	1		
R61	RES, DEP CAR, 91K +/-5%, 1/4W	441709	80031	CR251-4-5P91KT	1		
R62	RES, DEP CAR, 1K +/-5%, 1/4W	343426	80031	CR251-4-5P1KT	1		
R63	RES, DEP CAR, 1.3M +/-5%, 1/4W	442558	80031	CR251-4-5P1M3T	2		
R64	RES, DEP CAR, 1.3M +/-5%, 1/4W	442558	80031	CR251-4-5P1M3T	REF		
U50	IC, LIN, OP AMP, METAL CAN	288928	12040	LM308AH	1	1	
U51	IC, LIN, OP AMP, DUAL COMP, 8PDP	418566	89536	418566	1	1	
VR50	IC, LIN, LO-VOLTAGE REG	452771	89536	452771	1	1	
W50	CABLE, FLAT, 7 COND	494187	89536	494187	1		
W51	WIRE, ASSY	487637	89536	487637	1		

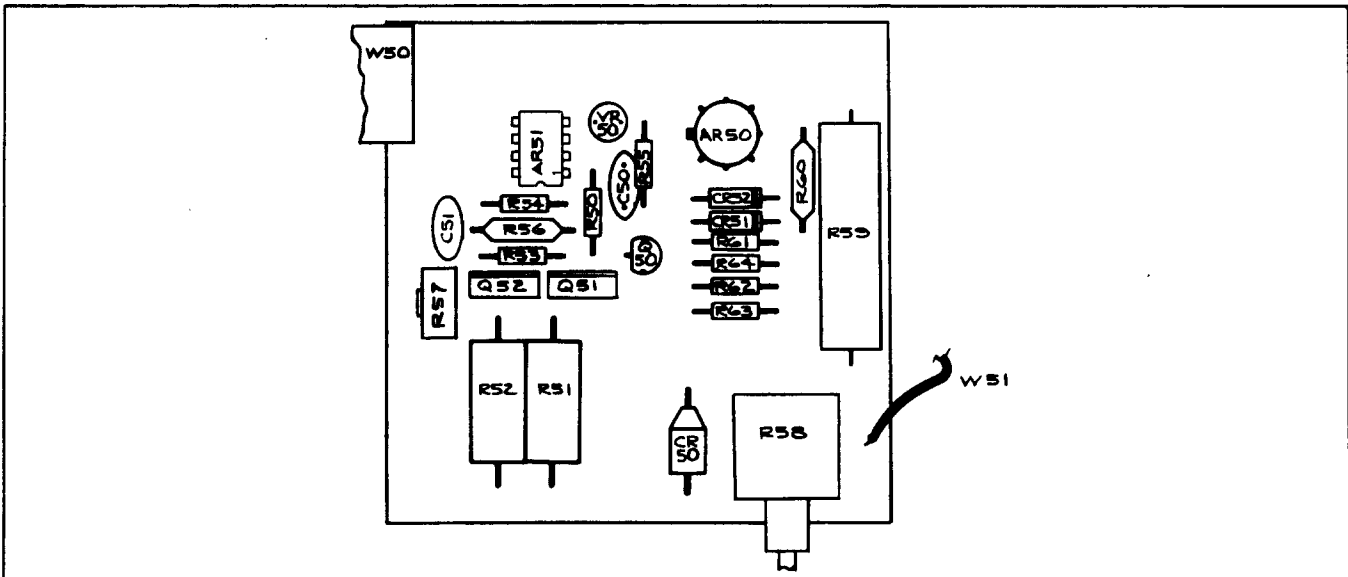

Figure 5-3. A2 Low Ohms PCB Assembly

Section 6

Option & Accessory Information

6-1. INTRODUCTION

6-2. This section of the manual contains information concerning the options and accessories available for use with your 8010A or 8012A Digital Multimeter. This information is divided into subsections. Each option is a subsection and all of the accessories are in one subsection. The location of an option or accessory is

facilitated by the use of unique paragraph and page numbering which corresponds with the option number. For example, all the accessory pages and paragraphs will be numbered 600-X but the pages and paragraphs of the -01 Option will be numbered 601-X. A list of replaceable parts and a component location diagram are provided with each option.

TABLE OF CONTENTS

OPTION/ MODEL NO.	DESCRIPTION	PAGE
	ACCESSORIES	600-1
	OPTIONS	
-01	Battery Option	601-1

Accessories

600-1. INTRODUCTION

600-2. This material describes the accessories available for your instrument and describes their basic use. For more detailed information, refer to the instruction sheet included with each accessory. When ordering an accessory, include the model number and name.

600-3. CARRYING CASE (C80)

600-4. The Model C80 Carrying Case, Figure 600-1, is a soft, vinyl plastic container, designed for the storage and transport of your instrument. The case provides your instrument with adequate protection against normal handling and storage conditions. A separate storage compartment is provided for test leads, power cord, and other compact accessories.

600-5. CARRYING CASE (C86)

600-6. The Model C86 Carrying Case, Figure 600-2, is a molded, polyethylene container with handle, designed for use in transporting your instrument. This rugged case provides your instrument with maximum protection against rough handling and adverse weather conditions. A separate storage compartment is provided for test leads, power cord and other compact accessories.

600-7. RACK MOUNTING KITS

600-8. Introduction

600-9. Three rack mounting kits are available for mounting your instrument in a standard 19-inch equipment rack. The kits, listed in Table 600-1 provide the option of either offset mounting, or side-by-side mounting.

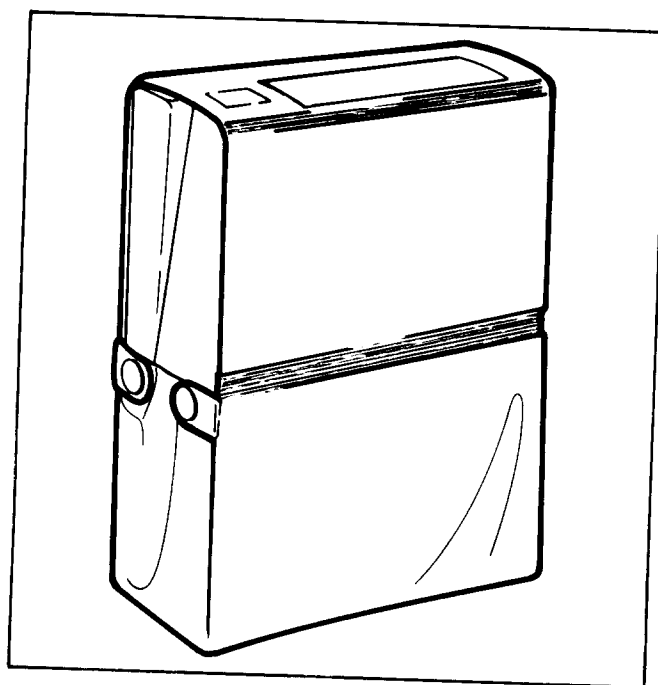

Figure 600-1. Model C80 Carrying Case

600-10. Installation Procedure

600-11. Installation instructions for each of the rack mounting kits are given in the following paragraphs. Use the procedure which corresponds to the model number of the kit being installed.

600-12. Offset and Center Mounting Kits (M00-200-611 and M00-200-612)

600-13. Use the following procedure when installing your instrument in the standard center or offset rack mounts.

1. Remove the carrying handle by removing the handle disc decals and the handle mounting screws.
2. Remove screw from rear of case and remove the case.
3. Install the side mounting brackets, as shown in Figure 600-3 and secure them to the mounting panel using the nuts provided.
4. Insert the front of the case through the opening on the back side of the mounting panel.
5. Install the handle mounting screws through the side brackets into the handle mounting bosses. Don't over tighten these screws.
6. Slide the instrument through the mounting panel and into the case. Install and tighten the retaining screw at the rear of the case.

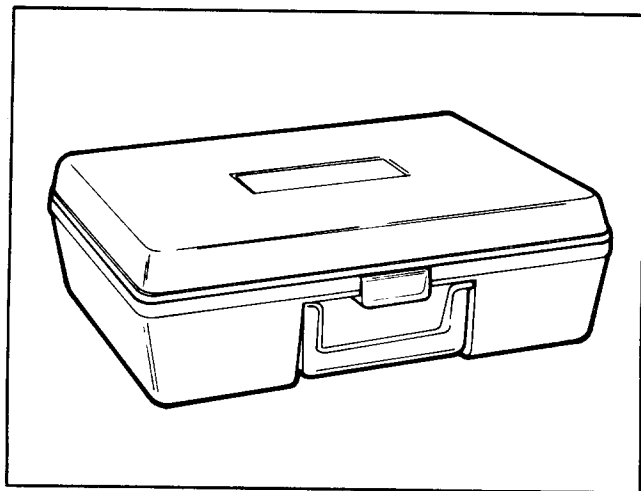

Figure 600-2. Model C86 Carrying Case

Table 600-1. Rack Mounting Kits

MOUNTING STYLE	MODEL NUMBER
Offset	M00-200-611
Center	M00-200-612
Side-By-Side	M00-200-613

600-14. Side-by-Side Mounting Kit (M00-200-613)

600-15. Use the following procedure for installation of your instrument into a side mounting rack.

600-2

1. Remove the carrying handles from both instruments by removing the handle disc decals and the handle mounting screws.
2. Remove the retaining screw from the rear of the cases and separate the instruments from their cases.
3. Install the center mounting bracket, as shown in Figure 600-4 and secure it to the mounting panel, using the nuts provided.
4. Install the clamp screw in the center mounting bracket, using the nuts and washers provided.
5. Insert the front of the instrument cases through the openings on the back side of the mounting panel. Make sure the case's handle mounting bosses are inserted into the clamp hole of the center mounting bracket.
6. Tighten the clamp screws.
7. Install the side mounting brackets and secure them to the front panel, using the nuts provided.
8. Install the handle mounting screws through the side brackets into the handle mounting bosses. Don't over tighten these screws.
9. Slide the instruments through the mounting panel and into their cases. Install and tighten the retaining screw at the rear of both cases.

600-16. PROBE ACCESSORIES

600-17. The following paragraphs describe the probe accessories. They are shown in Figure 600-5.

600-18. Touch & Hold Probe (Y8008)

600-19. The Touch and Hold Probe allows voltage, resistance and conductance readings to be held in the display of your instrument. Normal readings may be made by using the probe with the control switch in the out position. When the control switch is pressed, the COMMON terminal is connected to the Touch and Hold signal at the mA terminal. This stops the instrument clock, freezing the display. This feature is meant to be used for short time intervals. If you leave the display stopped for 1/2 to 1 hour, the outline of the displayed value will remain for a few hours. Stopping the display for extremely long periods of time may result in permanent damage to the LCD.

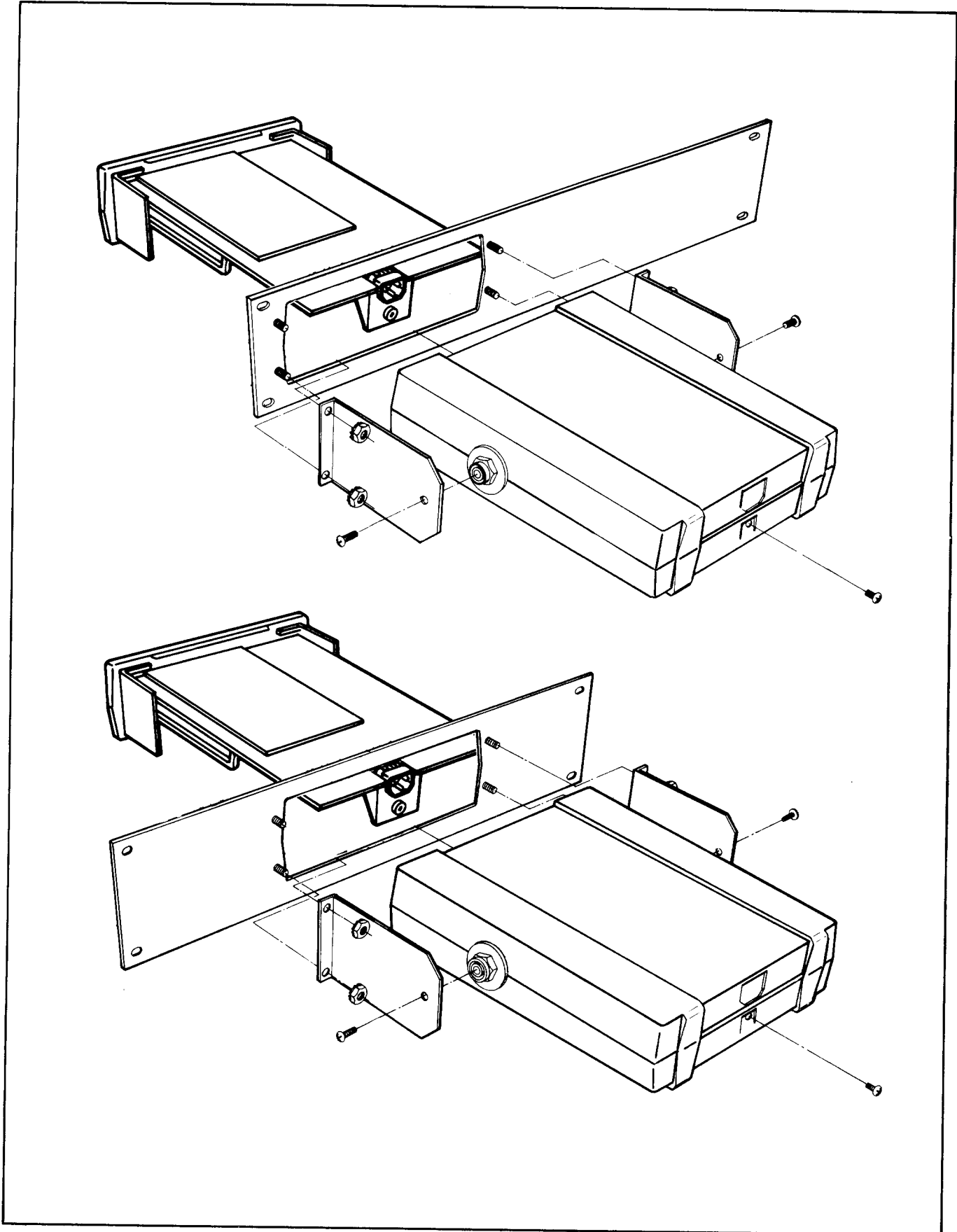

Figure 600-3. Rack Mounting Kits, Offset and Center Mounting

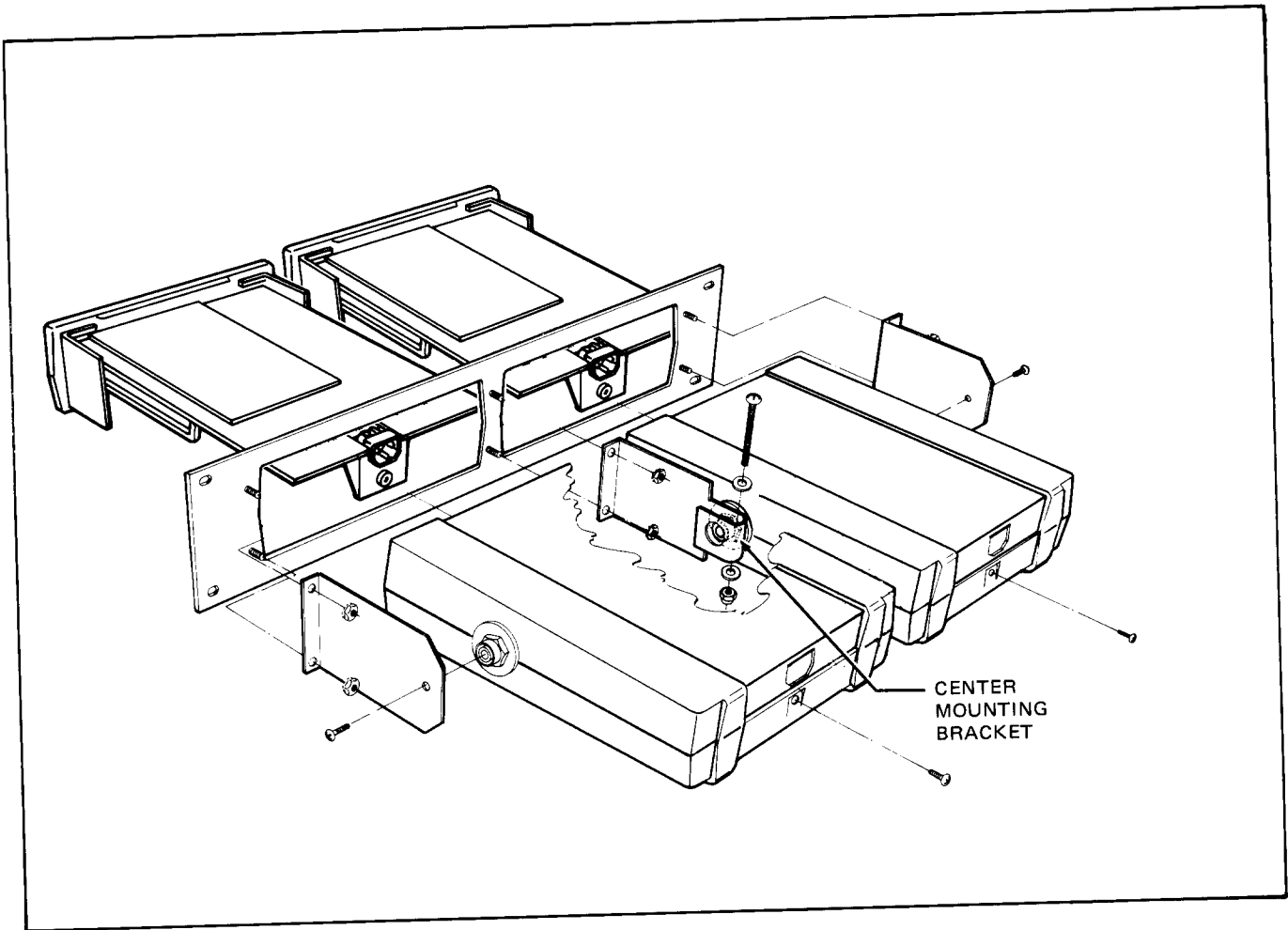

Figure 600-4. Rack Mounting Kit, Side-by-Side Mounting

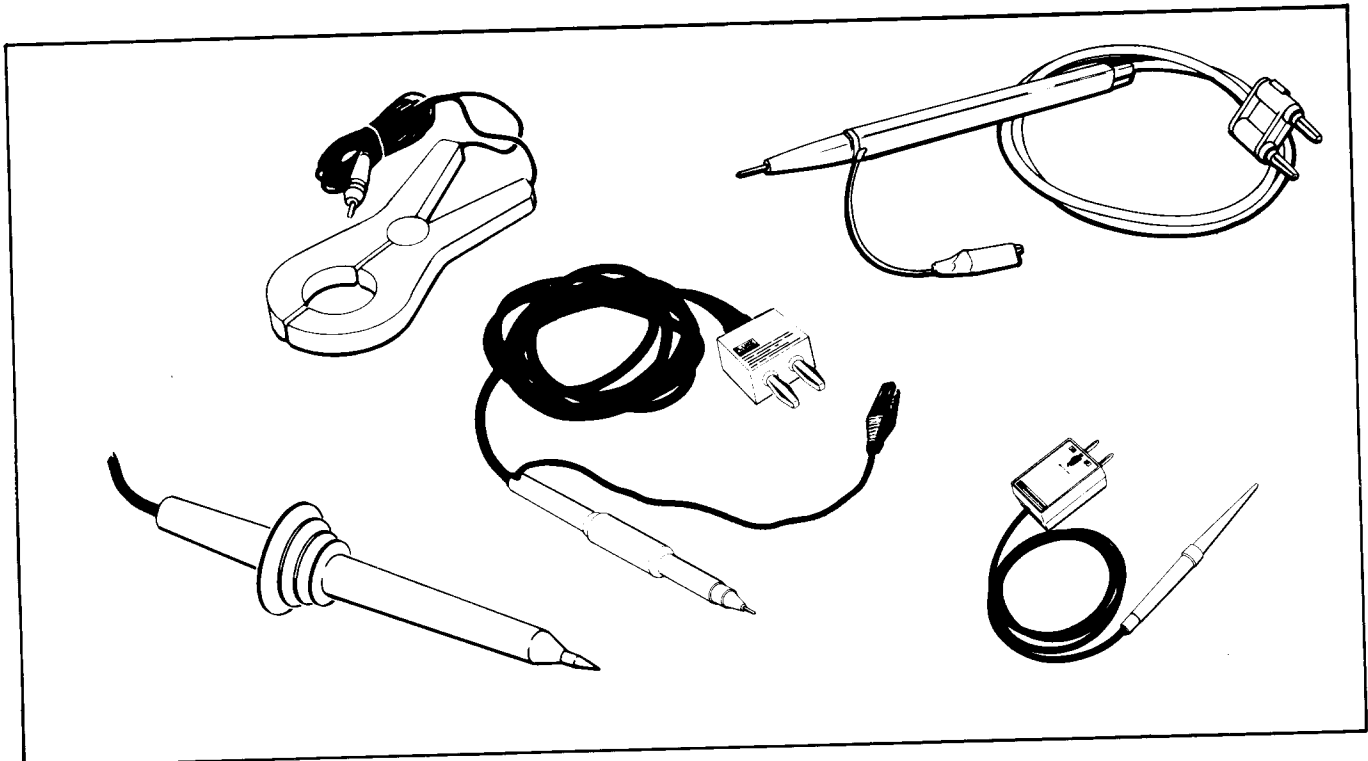

Figure 600-5. Probe Accessories

600-20. Temperature Probe (80T-150)

600-21. INTRODUCTION

600-22. The 80T-150 Temperature Probe converts your instrument into a direct-reading (1 mV dc/°) °C or °F thermometer. It is ideally suited for surface, ambient and liquid measurement, and lends itself easily to a wide range of design, troubleshooting and evaluation applications. A rugged, fast-responding probe-tip with a 350V dc standoff makes the 80T-150 one of the most versatile and easy-to-use temperature probes available.

600-23. SPECIFICATIONS

Range in °C/°F (field selectable by internal jumpers): -50°C to +150°C or -58°F to 302°F

Accuracy: ±1°C (1.8°F) from 0°C to 100°C, decreasing linearly to ±3°C (5.4°F) at -50°C and +150°C

Resolution: 0.1°C on 200 mV range

Voltage Standoff: 350V dc or peak ac

Power: Internal disposable battery; 1,000 hours of continuous use.

600-24. Current Transformer (80I-600)

600-25. INTRODUCTION

600-26. The Model 80I-600 extends the maximum 2A ac current measuring capability of your meter up to a maximum of 600 amps. A clamp-on transformer designed into the probe allows measurements to be made without breaking the circuit under test. In use, the current carrying conductor being measured serves as the transformer's primary while the 80I-600 serves as the secondary. Because of a high efficiency, quadrature type of winding, wire size and location of the conductor within the transformer jaws do not affect accuracy of the current measurement.

600-27. SPECIFICATIONS

Range: 2 to 600 A ac

Accuracy: ±3%

Frequency Response: 30 Hz to 1 kHz

Division Ratio: 1000:1

Insulation: 5 kV

Maximum Conductor Size: 2-inch diameter

600-28. High Voltage Probe (80K-40)

600-29. INTRODUCTION

600-30. The Model 80K-40 extends the voltage measurement capability of your meter up to 40 kV. Internally, the probe contains a special 1000:1 resistive divider. Metal film resistor with matched temperature coefficients comprise the divider, and provide the probe with its excellent accuracy and stability characteristics. Also, an unusually high input impedance (1000 MΩ) minimizes circuit loading, and thereby contributes to measurement accuracy.

600-31. SPECIFICATIONS

Voltage Range: 1 kV to 40 kV dc or peak ac, 28 kV rms ac.

Input Resistance: 1000 MΩ

Division Ratio: 1000:1

ACCURACY DC

Overall Accuracy: 20 kV to 30 kV ±2% (calibrated at 25 kV)

Upper Limit: Changes linearly from 2% at 30 kV to 4% at 40 kV

Lower Limit: Changes linearly from 2% at 20 kV to 4% at 1 kV

Accuracy AC (Overall): ±5% at 60 Hz

600-32. High Frequency Probe (81RF)

600-33. INTRODUCTION

600-34. The 81RF Probe extends the frequency range of your meter voltage measurements capability to include 100 kHz to 100 MHz inputs from 0.25 to 30V rms. It operates in conjunction with dc voltage ranges, and provides a dc output that is calibrated to be equivalent to the rms value of a sine wave input.

600-35. SPECIFICATIONS

Frequency Response: ±1 dB from 100 kHz to 100 MHz

Extended Frequency: Useful for relative reading from 20 kHz to Response 250 MHz

Response: Responds to peak value of input; calibrated to read rms value of a sine wave

Voltage Range: 0.25 to 30V rms

Maximum DC Input: 350V dc

Input Impedance: 12 MΩ shunted by 15 pF

-01 Option Battery Pack/Selectable Line Frequency Rejection

601-1. INTRODUCTION

601-2. This option replaces the standard power supply with a power supply that either operates off of line power or off of an installed battery pack. The option also replaces the crystal clock for the custom IC with two crystals and a selector switch. One crystal is used to reject 60 Hz noise and one crystal is used to reject 50 Hz noise. Your instrument will operate for 15 hours (typically) before the battery must be recharged.

601-3. THEORY OF OPERATION

601-4. The theory of operation will be illustrated by the Main PCB schematic in Section 8.

601-5. The battery power supply is shown on the schematic in the lower left hand corner just above the standard power supply schematic. The -01 Option power supply can be used with line voltages of 90V to 264V, 60 Hz or 50 Hz. Selector switch S2 should be positioned for high or low voltage depending upon the line voltage being used. F3 provides fuse protection for the power supply. Line power input is rectified, filtered and regulated. The output of the power supply acts as a current source for the battery. The battery determines the voltage level into the low power oscillator. Don't operate your instrument with the battery removed. The low power oscillator uses the fly-back transformer technique to boost the output voltage, +VDD(-VSS) to 10V. This in turn is converted to a +VA and -VA of $\pm 11.5V$.

601-6. When the battery voltage drops below 2.1V, the BT indicator will illuminate on the display. (This BT indicator will also illuminate briefly when the instrument is turned off.) After the BT indicator lights, you have at

least 1/2 hour (typically) before the accuracy of the instrument will be effected. Battery power is low.

NOTE

The AC functions consume a lot more power than the other functions. The battery charge may be too low for AC functions (BT displayed) and still be adequate for proper operation with other functions (BT not displayed).

601-7. The selectable line frequency rejection circuit is connected to pins 39 and 40 of the custom IC. This circuit replaces Y1. It consists of two crystals and a switch. The switch selects either the 50 Hz rejection crystal or the 60 Hz rejection crystal for the clock frequency reference. The position that S3 is set to before leaving the factory will be marked on the decal on the bottom of your instrument.

601-8. MAINTENANCE

601-9. Battery Replacement

601-10. Use the following procedure for removing and replacing batteries:

1. Disconnect line cord. Remove retaining screw at rear of instrument case, and remove instrument from case.
2. Turn the instrument upside down.
3. Unplug the red and black battery wires.
4. Apply pressure to the sides of the battery case to disconnect the battery case from the Main PCB.

5. Remove the blotting paper.
6. Replace the batteries with a new Fluke battery assembly.
7. Replace the blotting paper and connect the battery case back to the Main PCB.
8. Connect the battery wires to their appropriate connector on the Main PCB, red to +, black to -.
9. Replace the instrument in its case.

601-11. Fuse Replacement

601-12. Use the following procedure to replace the main power fuse, F3.

1. Perform the Calibration Access Procedure in Section 4.
2. F3 is located immediately in front of the power receptacle.
3. Replace F3 with 1/32A, Slo-Blo, 250V.

601-13. POWER SUPPLY CHECK

601-14. Use the following procedure to verify the power supply voltages of your instrument.

1. Place the POWER switch on the UUT in the ON position.
2. On the UUT, select the DC V function, 200V range.
3. Verify that the LCD displays $00.0 \pm 0.1V$.
4. With the DMM, verify that the power supply voltages listed in Table 601-1 are within the tolerances listed in Table 601-1.

601-15. REPLACEABLE PARTS

601-16. Table 601-2 is a list of replaceable parts for the -01 Option. Figure 601-1 is a component location diagram for the -01 Option.

Table 601-1. -01 Option Power Supply Voltages

TEST POINT	VOLTAGE FUNCTION	VOLTAGE LEVELS DURING BATTERY OPERATION	REMARKS
TP5 TP7 TP9	-VSS +VDD	$-2.1 \pm 0.4V$ $-6.5 \pm 1V$ $+2.9 \pm 0.3V$	
TP8 TP10	-VA +VA	$-11.5 \pm 1V$ $+11.5 \pm 1V$	An ac function must be selected to measure -VA and +VA.
TP13 (+) to TP9 TP14 (+) to TP13		+2.4V nominal $+1.25 \pm 0.05V$	Variable, 2.0 to 3.0V, depending upon battery charge level. Determines battery charging current through R24.

Table 601-2. A1 Main PCB Assembly (-01 Option)

ITEM NO.	DESCRIPTION	FLUKE STOCK NO.	MFG SPLY CODE	MFG PART NO. OR TYPE	TOT QTY	REC QTY	USE CDE
A1	MAIN PCB ASSY, -01 OPTION FIGURE 601-1 (8010A-4011)	ORDER	NEXT	HIGHER ASSY			
AR1	IC,LIN OP-AMP	418780	12040	LF351N	1	1	
C1	CAP,VAR,1.5PF-0.25PF,200V	218206	72982	530-000	2	1	
C2	CAP,MICA,150PF +/-5%,500V	148478	72136	DM15F151J	2		
C3	CAP,MICA,120PF +/-5%,500V	148486	72136	DM15F121J	1		
C4	CAP,VAR,1.5PF-0.25PF,200V	218206	72982	530-000	REF		
C5	CAP,MICA,2200PF +/-5%,500V	148346	72136	DM19F222J	REF		
C6	CAP,MYLAR,0.047UF +/-10%,250V	162008	73445	C280AMAE47K	1		
C7	CAP,MICA,150PF +/-5%,500V	148478	72136	DM15F151J	REF		
C8	CAP,TA,10UF +/-20%,15V	193623	56289	196D106X0015KA1	3		
C9	CAP,POLY,0.622UF +/-10%,100V	448183	03797	0.22/10/1000-7	1		
C10	CAP, ELECT, 22UF -10/+75%, 16V	436840	89536	436840	1	1	
C11	CAP, MYLAR, 0.047UF +/-10%, 250V	446773	89536	446773	2		
C12	CAP,MICA,470PF +/-5%,500V	148429	72136	DM19E471J	1		
C13	CAP, MYLAR, 0.047UF +/-10%, 250V	446773	89536	446773	REF		
C14	CAP,POLY,0.1UF +/-10%,2500V	446781	89536	446781	1		
C15	CAP,POLY,0.22UF +/-10%,100V	436113	73445	C280MAH1A220K	1		
C16	CAP,CER,0.01UF +/-20%,100V	149153	56289	C023B101F103M	2		
C17	CAP,CER,500PF +/-10%,500V	105692	56289	C067B102E501K	1		
C18	CAP,TA,2.2UF +/-20%,20V	161927	56289	196D225X0020HA1	1		
C19	CAP,TA,10UF +/-20%,15V	193623	56289	196D106X0015	REF		
C20	CAP, ELECT, 2200UF +75/-10%, 16V	474981	89536	474981	1	1	
C21	CAP, ELECT, 22UF +75/-10%, 16V	436840	89536	436840	2	1	
C22	CAP, ELECT, 2200UF +75/-10%, 16V	435990	89536	435890	1	1	
C23	CAP, TA, 2.2UF +/-20%, 20V	161927	56289	1960225X0020HA1	2		
C24	CAP, TA, 2.2UF +/-20%, 20V	161927	56289	1960225X0020HA1	REF		
C25	CAP, CER, 1000PF +/-10%, 500V	357806	56289	C016B102G102K	1		
C26	CAP, ELECT, 220UF +75/-10%, 16V	435990	89536	435990	2	1	
C27	CAP, ELECT, 220UF +75/-10%, 16V	435990	89536	435990	REF		
C28	CAP, ELECT, 22UF +75/-10%, 16V	436840	89536	436840	REF		
C29	CAP, TA, 10UF +/-20%, 15V	193623	56289	196D106X0015KA1	1		
C33	CAP,TA,10UF +/-20%,15V	193623	56289	196D106X0015	REF		
C34	CAP,CER,0.01UF +/-20%,100V	149153	56289	C023B101F103M	REF		
CR1	DIODE,SI,RECT. 2A,50V	347559	05277	IN5400	1		
CR2	DIODE,SI,LO-CAP,LO-LEAK	348177	07263	FD7223	2	1	
CR3	DIODE,SI,LO-CAP,LO-LEAK	348177	07263	FD7223	REF		
CR5	DIODE, HI-SPEED SW	203323	07910	1N4448	2	1	
CR6	DIODE, SI, RECT, 1A	343491	01295	1N4002	2	1	
CR7	DIODE, SI, RECT, 1A	343491	01295	1N4002	REF		
CR8	DIODE, HI-SPEED SW	203323	07910	1N4448	REF		
DS1	LIQUID CRYSTAL DISPLAY (LCD)	453100	89536	453100	1		
F1	FUSE, FAST-BLO, 2A, 250V AMERICAN SIZE, 1 X 1/4 METRIC SIZE, 20MM X 5MM	376582 460972	71400 89536	AGX2 460972	1 1	5 5	
F2	FUSE, FIBRE, 3A, 600V	475004	71400	BBS-3	1	5	
F3	FUSE, SLO-BLO, 1/32A	163022	71400	MDL1-32	1	5	
H1	PUSH ROD	479634	89536	479634	1		
H2	GROMMET,POLY	435974	06915	PG-S-2	1	1	
H3	SCREW,RHP,4-40 X 1/4	256156	89536	256156	4		

ITEM NO.	DESCRIPTION	FLUKE STOCK NO.	MFG SPLY CODE	MFG PART NO. OR TYPE	TOT QTY	REC QTY	USE CDE
H4	SCREW, RHP, #5 X 5/16	494641	89536	494641	2		
H5	RIVET	233932	83058	MS49338-2	6		
H6	SCREW, RHP, 6-32 X 3/16	114942	89536	114942	2		
H7	INSULATOR	495044	89536	495044	1		
H8	SCREW	114942	89536	114942	1		
H9	SPACER, STANDOFF	347526	89536	347526	1		
H10	GROMMET	493015	89536	493015	REF		
J1	CONN, PCB	233411	00779	60599-3	1		
JA1	RECEPTACLE, AC	471029	89536	471029	1		
MP1	PANEL, FRONT	ORDER	NEXT	HIGHER ASSEMBLY	1		
MP2	SHIELD, TOP	471037	89536	471037	1		
MP3	SHIELD, BOTTOM	471045	89536	471045	1		
MP4	BRACKET, LCD	471730	89536	471730	1		
MP5	BEZEL, LCD	479642	89536	479642	1		
MP6	BUTTON, SWITCH, GREEN	445197	89536	445197	1		
MP7	BUTTON (S4 THRU S7)	425900	89536	425900	2		
MP8	BUTTON (S8 THRU S13)	426759	89536	426759	6		
MP9	SPRING, COMP, SS	422824	84830	LC-0226-3	1	1	
MP10	RETAINER, BATTERY	471052	89536	471052	1		
MP11	PAD, ABSORBENT	483610	89536	483610	1		
MP12	BATTERY ASSY	487975	89536	487975	1		
MP13	HEAT SINK	473785	13103	6046PB	1		
Q1	XSTR, SI, NPN	483859	89536	483859	4	1	
Q2	XSTR, SI, NPN	483859	89536	483859	REF		
Q3	XSTR, SI, NPN	483859	89536	483859	REF		
Q4	XSTR, SI, PNP	195974	89536	195974	2	1	
Q5	XSTR, SI, PNP	195974	89536	195974	REF		
Q6	XSTR, SI, PNP	418707	07910	MPS6562	1	1	
Q7	XSTR, SI, NPN	168716	89536	168716	1	1	
Q8	XSTR, SI, PNP	195974	89536	195974	1	1	
Q9	XSTR, SI, NPN	483859	89536	483859	REF		
R1	RES, COMP, 100K +/-10%, 1W	109397	01121	GB1031	1		
R2	RES, COMP, 1K +/-10%, 2W	474080	01121	HB1021	1		
R3	RES, MF, 1K +/-0.1%, 1/8W	474445	91637	CMF551001B	1		
R4	RES, VAR, CRMT, 200 +/-10%, 1/2W	474973	89536	474973	1	1	
R5	RES, DEP CAR, 1M +/-5%, 1/4W	348987	80031	CR251-4-5P1MT	2		
R6	RES, DEP CAR, 100 +/-5%, 1/4W	348771	80031	CR251-4-5P100ET	1		
R7	RES, MF, 900 +/-0.1%, 1/8W	461988	89236	461988	1		
R8	RES, MF, 90.0 +/-0.1%, 1/8W	461970	89536	461970	1		
R9	RES, WW, 9.000 +/-0.15%, 3W	461962	89536	461962	1		
R10	RES, FXD, 0.01 +/-0.25%, 1W	461780	80031	461780	1		
R11	RES, COMP, 22M +/-10%, 1/2W	108233	01121	HB2251	2		
R12	RES, COMP, 22M +/-5%, 1/4W	221986	01121	CB2255	1		
R13	RES, DEP CAR, 1 +/-5%, 1/4W	357665	80031	CR251-4-5PIET	1		
R14	RES, COMP, 100K +/-5%, 2W	285056	01121	HB1045	1		
R15	RES, DEP CAR, 15 +/-5%, 1/4W	348755	80031	CR251-4-5PI5ET	1		
R16	RES, COMP, 1M +/-10%, 1W	109793	01121	GB1051	1		
R17	RES, DEP CAR, 220K +/-5%, 1/4W	348953	80031	CR251-4-5P220KT	1		
R18	RES, DEP CAR, 1K +/-5%, 1/4W	343426	80034	CR251-4-5PIKT	1		
R19	RES, VAR, CRMT, 5K +/-10%, 1/2W	478883	89536	478883	1	1	

Table 601-2. A1 Main PCB Assembly (-01 Option) (cont)

ITEM NO.	DESCRIPTION	FLUKE STOCK NO.	MFG SPLY CODE	MFG PART NO. OR TYPE	TOT QTY	REC QTY	USE CDE
R20	RES, DEP CAR, 2.2M +/-5%, 1/4W	342659	80031	CR251-4-5P2M2T	1		
R21	RES, VAR, 1M +/-10%, 1/2W	485052	89536	485052	1		
R22	RES, DEP CAR 470K +/-5%, 1/4W	342634	80031	CR251-4-5P470KT	1		1
R23	RES, DEP CAR, 1M +/-5%, 1/4W	348987	80031	CR251-4-5P1MT	1		
R24	RES, COMP, 8.2 +/-5%, 1/2W	159590	01121	EB8G25	REF		
R25	RES, DEP CAR, 3.3K +/-5%, 1/4W	348813	80031	CR251-4-5P3K3	1		
R26	RES, DEP CAR, 47 +/-5%, 1/4W	441592	80031	CR251-4-5P47E	1		
R27	RES, DEP CAR, 1 +/-5%, 1/4W	357665	80031	CR251-4-5P1E	1		
R28	RES, DEP CAR, 100 +/-5%, 1/4W	348771	80031	CR251-4-5P100E	1		
R29	RES, DEP CAR, 4.7K +/-5%, 1/4W	348821	80031	CR251-4-5P4K7	1		
R30	RES, DEP CAR, 4.7K +/-5%, 1/4W	348821	80031	CR251-4-5P4K7T	1		
R31	RES, DEP CAR, 100K +/-5%, 1/4W	348920	80031	CR251-4-5P100KT	1		
R32	RES, COMP, 22M +/-10%, 1/2W	108233	01121	HB2251	REF		
RT1	RES, CL, 1K +/-40%, 2W, 25 DEG C	446849	50157	180010200	1		
RV1	VARISTOR, 430V +/-10%	447672	09214	V430MA7B	3		1
RV2	VARISTOR, 430V +/-10%	447672	09214	V430MA7B	REF		
RV3	VARISTOR, 430V +/-10%	447672	09214	V430MA7B	REF		
S1	SWITCH, POWER	473736	89536	473736	1		
S2	SWITCH, SLIDE	453365	34828	G1-116-0001-G20-52	2		1
S3	SWITCH, SLIDE	453365	34828	G1-116-0001-G20-52	REF		
S20	SWITCH, ASSY. (S4 THRU S13)	473322	89536	473322	1		
T2	XFMR, POWER	490110	89536	490110	1		
T3	XFMR, DC-DC CONVERTER	478453	89536	478453	1		
U1	RES, NETWORK, 10.0M, 101K, 11.1K	461483	89536	461483	1		1
U2	RES, NETWORK, .100, .900	461491	89536	461491	1		1
U3	IC, C-MOS, A/D CONVERTER	429100	89536	429100	1		1
U4	IC, FW. RECT. BRIDGE, 50V-1000V, 1A	418582	83003	VM08	1		1
U5	RES, NETWORK, 25 DEG.C, +/-5%, 1/8W	474999	89536	474999	1		1
U6	IC, COS/MOS, QUAD XOR GATE	355222	89536	355222	1		1
U7	IC, LIN, 2.5V BAND-GAP REF	472845	04713	MC1403V	1		1
U8	HYBRID RMS CONVERTER	480897	89536	480897	1		1
U9	RECT, BRIDGE, 1A, 50V	418582	89536	418582	1		1
U10	IC, LIN VOLTAGE REGULATOR	473793	12040	LM317MP	1		1
VR1	DIODE, ZENER	473744	07910	1N5240	1		1
VR2	DIODE, ZENER, 4.3V	180455	07910	IN749A	1		1
W1	CONNECTOR, ELASTOMERIC	453092	18565	22989	1		
W10	CONNECTOR, ELASTOMERIC	453092	18565	22989	1		
XF1	FUSE HOLDER ASSEMBLY	ORDER	FOR	CORRECT SOURCE	REF		
	100V, 115V SOURCE	487967	89536	487967	1		
	230V SOURCE	487959	89536	487959	1		
XF3	CLIP, FUSE	485219	91833	3529	2		
XU3	SOCKET, IC; 40 PIN	429282	09922	DILB40P-108	1		
Y2	CRYSTAL, 60HZ, 3.89MHZ	447615	89536	483610	1		
Y3	CRYSTAL, 50HZ, 3.200MHZ	460550	89536	460550	1		

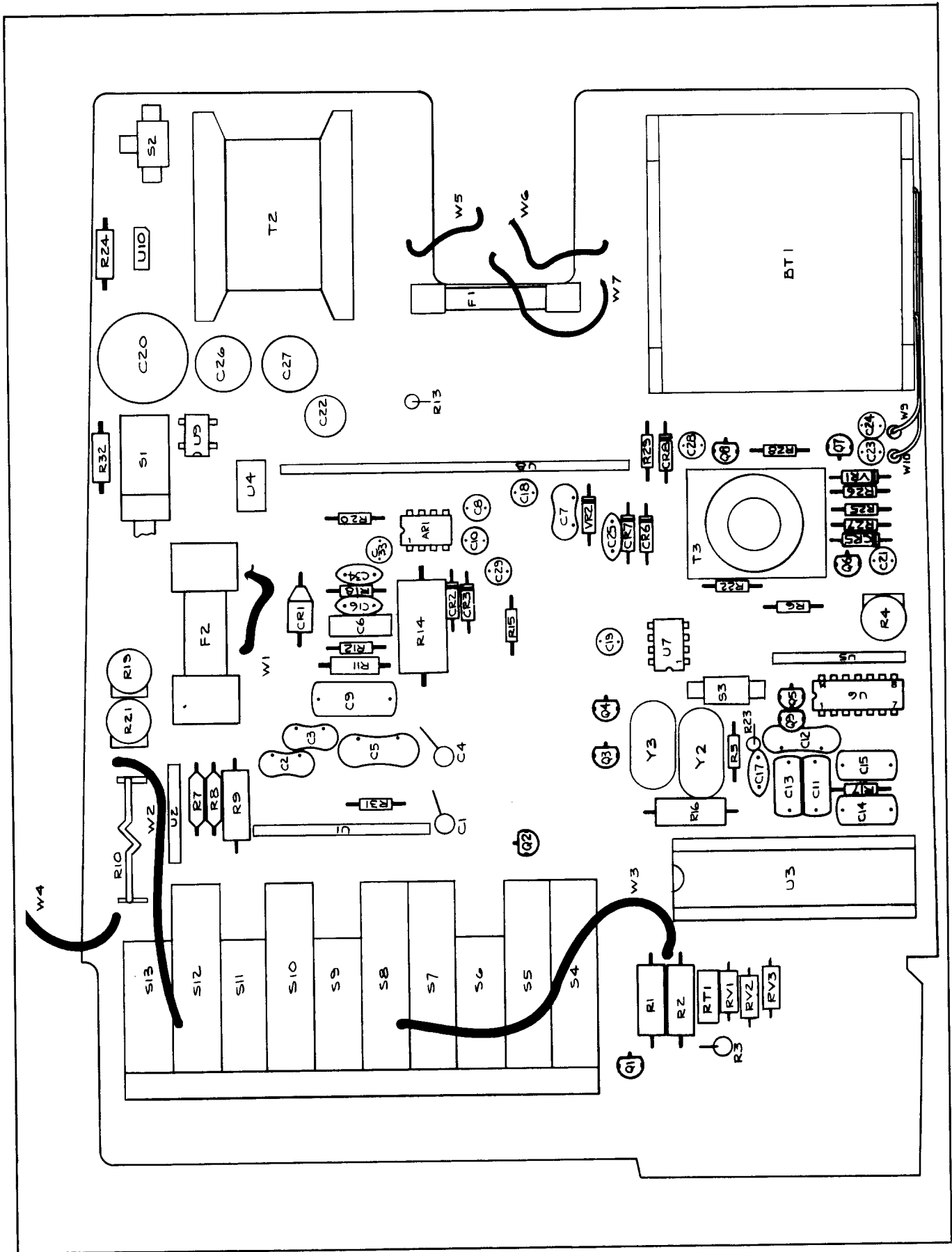

Figure 601-1. A1 Main PCB Assembly (-01 Option)

Section 7

General Information

7-1. This section of the manual contains generalized user information as well as supplemental information to the List of Replaceable parts contained in Section 5. The following information is presented in this section:

List of Abbreviations

Fluke Technical Service Centers — U.S. and Canada

Sales and Service Locations — International

Sales Representatives — U.S. and Canada

List of Abbreviations and Symbols

A or amp	ampere	H	henry	pF	picofarad
ac	alternating current	hd	heavy duty	pn	part number
af	audio frequency	hf	high frequency	(+) or pos	positive
a/d	analog-to-digital	Hz	hertz	pot	potentiometer
assy	assembly	IC	integrated circuit	p-p	peak-to-peak
AWG	american wire gauge	if	intermediate frequency	ppm	parts per million
B	bel	in	inch(es)	PROM	programmable read-only memory
bcd	binary coded decimal	intl	internal	psi	pound-force per square inch
°C	Celsius	I/O	input/output	RAM	random-access memory
cap	capacitor	k	kilo (10 ³)	rf	radio frequency
ccw	counterclockwise	kHz	kilohertz	rms	root mean square
cer	ceramic	kΩ	kilohm(s)	ROM	read-only memory
cermet	ceramic to metal(seal)	kV	kilovolt(s)	s or sec	second (time)
ckt	circuit	lf	low frequency	scope	oscilloscope
cm	centimeter	LED	light-emitting diode	SH	shield
cmrr	common mode rejection ratio	LSB	least significant bit	Si	silicon
comp	composition	LSD	least significant digit	serno	serial number
cont	continue	M	mega (10 ⁶)	sr	shift register
crt	cathode-ray tube	m	milli (10 ⁻³)	Ta	tantalum
cw	clockwise	mA	milliampere(s)	tb	terminal board
d/a	digital-to-analog	max	maximum	tc	temperature coefficient or temperature compensating
dac	digital-to-analog converter	mf	metal film	tcxo	temperature compensated crystal oscillator
dB	decibel	MHz	megahertz	tp	test point
dc	direct current	min	minimum	u or μ	micro (10 ⁻⁶)
dmm	digital multimeter	mm	millimeter	uhf	ultra high frequency
dvm	digital voltmeter	ms	millisecond	us or μs	microsecond(s) (10 ⁻⁶)
elect	electrolytic	MSB	most significant bit	uut	unit under test
ext	external	MSD	most significant digit	V	volt
F	farad	MTBF	mean time between failures	v	voltage
°F	Fahrenheit	MTTR	mean time to repair	var	variable
FET	Field-effect transistor	mV	millivolt(s)	vco	voltage controlled oscillator
ff	flip-flop	mv	multivibrator	vhf	very high frequency
freq	frequency	MΩ	megohm(s)	vlf	very low frequency
FSN	federal stock number	n	nano (10 ⁻⁹)	W	watt(s)
g	gram	na	not applicable	ww	wire wound
G	giga (10 ⁹)	NC	normally closed	xfmr	transformer
gd	guard	(-) or neg	negative	xstr	transistor
Ge	germanium	NO	normally open	xtal	crystal
GHz	gigahertz	ns	nanosecond	xtlo	crystal oscillator
gmV	guaranteed minimum value	opnl ampl	operational amplifier	Ω	ohm(s)
gnd	ground	p	pico (10 ⁻¹²)	μ	micro (10 ⁻⁶)
		para	paragraph		
		pcb	printed circuit board		

U.S. SALES OFFICES for all Fluke products

AK, Anchorage

Harry Lang & Associates
1371 Hillcrest Drive #303
Anchorage, AK 99503
(907) 279-5741

AL, Huntsville

John Fluke Mfg. Co., Inc.
3322 Memorial Parkway
Huntsville, AL 35801
(205) 881-6220
(404) 396-3224 (Atlanta)

AZ, Tempe

John Fluke Mfg. Co., Inc.
2125 S. 48th Street
Suite 104
Tempe, AZ 85282
(602) 967-8724
(602) 790-9881 (Tucson)

CA, Los Angeles

John Fluke Mfg. Co., Inc.
20902 South Bonita St.
Carson, CA 90746
(213) 538-3900 or
(714) 761-2449

CA, Santa Clara

John Fluke Mfg. Co., Inc.
2300 Walsh Ave., Bldg. K
Santa Clara, CA 95050
(408) 727-0513

CA, Tustin

John Fluke Mfg. Co., Inc.
15445 Red Hill Ave., Suite F
Tustin, CA 92680
(714) 838-8863
(714) 226-1254 (San Diego)

CO, Denver

John Fluke Mfg. Co., Inc.
1980 South Quebec St. #4
Denver, CO 80231
(303) 750-1222

CT, Hartford

John Fluke Mfg. Co., Inc.
124 Hebron Ave.
Glastonbury, CT 06033
(203) 633-0777

FL, Orlando

John Fluke Mfg. Co., Inc.
940 N. Fern Creek Ave.
Orlando, FL 32803
(305) 896-4881

HI, Honolulu

EMC Corporation
2979 Ualena St.
Honolulu, HI 96819
(808) 836-1138

IA, Iowa City

John Fluke Mfg. Co., Inc.
1027 Hollywood Blvd., #309
Iowa City, IA 52240
(319) 354-2811

IL, Chicago

John Fluke Mfg. Co., Inc.
1400 Hicks Road
Rolling Meadows, IL 60008
(312) 398-0850

IN, Indianapolis

John Fluke Mfg. Co., Inc.
5610 Crawfordsville Rd.
Suite 802
Indianapolis, IN 46224
(317) 244-2456

KA, Kansas City

John Fluke Mfg. Co., Inc.
4550 West 109th St.
Suite 130
Shawnee Mission, KA 66211
(913) 381-9800

MA, Burlington

John Fluke Mfg. Co., Inc.
25 "B" Street
Burlington MASS
(617) 273-4674

MD, Rockville

John Fluke Mfg. Co., Inc.
5640 Fishers Lane
Rockville, MD 20852
(301) 770-1570
(301) 792-7060 (Baltimore)

MI, Detroit

John Fluke Mfg. Co., Inc.
13955 Farmington Rd.
Livonia, MI 48154
(313) 522-9140

MN, Minneapolis

John Fluke Mfg. Co., Inc.
7373 West 147th Street
Suite 196
Apple Valley, MN 55124
(612) 432-9400

MO, St. Louis

John Fluke Mfg. Co., Inc.
300 Brookes Dr., Suite 100
Hazelwood, MO 63042
(314) 731-3388

NC, Greensboro

John Fluke Mfg. Co., Inc.
1310 Beaman Place
Greensboro, NC 27408
(919) 273-1918

NJ, Paramus

John Fluke Mfg. Co., Inc.
P.O. Box 930
West 75 Century Road
Paramus, NJ 07652
(201) 262-9550

NM, Albuquerque

John Fluke Mfg. Co., Inc.
1108 Alvarado Drive N.E.
Albuquerque, NM 87110
(505) 265-8431

NY, Rochester

John Fluke Mfg. Co., Inc.
4515 Culver Road
Rochester, NY 14622
(716) 266-1400

OH, Cleveland

John Fluke Mfg. Co., Inc.
7830 Freeway Circle
Middleburg Heights, OH 44130
(216) 234-4540

OH, Dayton

John Fluke Mfg. Co., Inc.
4756 Fishburg Rd.
Dayton, OH 45424
(513) 233-2238

OR, Portland

John Fluke Mfg. Co., Inc.
18360 S.W. Springfield Lane
Aloha, OR 97007
(503) 642-1342

PA, Philadelphia

John Fluke Mfg. Co., Inc.
1010 West 8th Ave., Suite H
King of Prussia, PA 19406
(215) 265-4040
(412) 261-5171 (Pittsburgh)

TX, Austin

John Fluke Mfg. Co., Inc.
111 W. Anderson Lane
Suite 213
Austin, TX 78752
(512) 478-9901
(512) 340-2621 (San Antonio)

TX, Dallas

John Fluke Mfg. Co., Inc.
14400 Midway Road
Dallas, TX 75234
(214) 233-9990

TX, Houston

John Fluke Mfg. Co., Inc.
1014 Wirt Road, Suite 270
Houston, TX 77055
(713) 683-7913

UT, Salt Lake City

John Fluke Mfg. Co., Inc.
782 East 8325 Street
Sandy, UT 84070
(801) 566-4864

WA, Seattle

John Fluke Mfg. Co., Inc.
975 Industry Drive
Seattle, WA 98188
(206) 575-3765

For more information on Fluke products or Sales Offices you may dial (800) 426-0361 toll-free in most of U.S.
From Alaska, Hawaii, or Washington, phone (206) 774-2481. From other countries phone (206) 774-2398.

INTERNATIONAL SALES OFFICES

Argentina •

Coasin, S.A.
Virrey del Pino 4071
Buenos Aires, Argentina
Tel: 525130, TLX: 390122284

Australia •

Elmeasco Instruments Pty Ltd.
P.O. Box 30, Concord, N.S.W.
Australia 2137
Tel: (2) 736-2888, TLX: 79025887

Elmeasco Instruments Pty Ltd.
P.O. Box 107
Mt. Waverley, VIC. 3149

Australia

Tel: 233-4044

TLX: 36206 (ELMVIC)

Elmeasco Instruments Pty Ltd.

Professional Suite's Bldg.

B.P.O. Box 2360

Brisbane, 4001, Australia

Tel: (07) 229-3161

Elmeasco Instruments Pty Ltd.

P.O. Box 1240

G.P.O. Adelaide 5001

South Australia

Elmeasco Instruments Pty. Ltd.

P.O. Box 95, Gosnells

West Australia 6110

Tel: (09) 348-3362

Austria ■

Walter Rekersch

Elektronische Gerate GmbH & Co.

Vertriebs-KG., Obachgasse 28

A-1220 Vienna, Austria

Tel: (0222) 23555 TLX: 134759

Belgium ■

Fluke (Belgium) S.A./N.V.

6, Rue de Geneve

1140 Brussels, Belgium

Tel: (2) 2164090, TLX: 26312

Bolivia •

Coasin Bolivia S.R.L.

Casilla 7295, La Paz, Bolivia

Tel: 40962

Brazil •

Arotec S.A.

Industria e Comercio

Av. Pacaembu 811

01234 Sao Paulo S.P., Brazil

Tel: (011) 826-2266, TLX: 1122207

Arotec S.A.

Rua Araguari, 1705 s/402

30.000 Belo Horizonte M.G., Brazil

Tel: 335-7735

Arotec S.A.

Av. Rio Branco, 277, Grupo 1309

02000 Rio de Janeiro, R.J., Brazil

Tel: (021) 242-9776

Brunei •

Rank O'Connor's (PTE) Limited

No. 8, BK.D

Surfri Shop House Complex

Mile 1, Jalong Tutong

Bandar Seri Begawan, Brunei

Tel: 26680

Bulgaria ■

Amtest Associates Ltd.

P.O. Box 55

Addlestone, Surrey KT15 1DU

United Kingdom

Tel: Weybridge (932) 52121

TLX: 928855

Canada •

Allan Crawford Assoc., Ltd.

#14 1935 30th Ave. N.E.

Calgary, Alberta T2E 6Z5

Tel: (403) 230-1341

Allan Crawford Assoc., Ltd.

3795 William Street

Burnaby, British Columbia V5C 3H3

Tel: (604) 294-1326

Allan Crawford Assoc., Ltd.

192 Joseph Zatzman Dr.

Suite 4

Burnside Industrial Park

Dartmouth, Nova Scotia B3B 1N4

Tel: (902) 463-9360

Allan Crawford Assoc., Ltd.

881 Lady Ellen Place

Ottawa, Ontario K1Z 5L3

Tel: (613) 722-7682

Allan Crawford Assoc., Ltd.

6503 Northam Drive

Mississauga, Ontario L4V 1J5

Tel: (416) 678-1500

Allan Crawford Assoc., Ltd.

7018 cote de Liesse

St. Laurent, Quebec H4T 1E7

Tel: (514) 731-8564

Chad ■

Fluke (Holland) B.V.

P.O. Box 5053, Zevenheuvelenweg 53

5004 EB Tilburg, Netherlands

Tel: (013) 673973, TLX: 52237

Chile •

Intronica Chile Ltda.

Manuel Montt 024 - Of. D

Casilla 16228, Santiago 9, Chile

Tel: 44940

TLX: No 40301 Cab. Publ.,

Attn: Intronica Chile

China, People's Republic of •

Fluke International Corporation

P.O. Box 43210

Mountlake Terrace, WA 98043

Tel: (206) 774-2398

TLX: 152662 JOHNFLUKE MTLT

Colombia •

Coasin Ltda.

Carrera 13, No. 37-37, Of. 401

Ap. Aero 29583

Bogota DE, Colombia

Tel: 232-45-32, TLX: 45787

Cyprus ■

Chris Radiovision Ltd.

P.O. Box 1989, Nicosia, Cyprus

Tel: 66121, TLX: 2395

Czechoslovakia ■

Amtest Associates Ltd.

P.O. Box 55

Addlestone, Surrey KT15 1DU

United Kingdom

Tel: Weybridge (932) 52121

TLX: 928855

Denmark ■

Tage Olsen A/S

Ballerup Byvej 222

DK - 2750 Ballerup, Denmark

Tel: (2) 658111, TLX: 35293

Ecuador •

Protoco Coasin Cia., Ltda.

Edificio "Jerico"

Ave. 12 de Octubre #2285 y

Ave. Orellana (Planta Baja)

Quito, Ecuador

Tel: 529684, TLX: 2865 Protec Ed

Protoco Coasin Cia., Ltda.

Calderon 103Y Malecon

Casilla #9733

Guayaquil, Ecuador

Tel: 526093

Egypt and Sudan ■

Lotus Engineering Organisation

P.O. Box 1252

22, Kaft El Nil

Cairo, Egypt

Tel: 971617, TLX: 92504

Eire (Republic of Ireland) ■

EURO Electronics

32 Brews Hill

Naven, County Meath, Ireland

Tel: 46-23577, TLX: 3182

Ethiopia ■

Fluke (Holland) B.V.

P.O. Box 5053, Zevenheuvelenweg 53

5004 EB Tilburg, Netherlands

Tel: (013) 673973, TLX: 52237

Finland ■

Oy Findip AB, Teollisuustie 7

02700 Kauniainen, Finland

Puh: (0) 5052255

TLX: 123129

France ■

M.B. Electronique S.A.

Rue Fourny 606, Z1 Centre

78530 BUC

B.P. No. 31

78530 BUC, France

Tel: (3) 9568131, TLX: 695414

German Democratic Republic ■

Amtest Associates Ltd.

P.O. Box 55

Addlestone, Surrey KT15 1DU

United Kingdom

Tel: Weybridge (932) 52121

TLX: 928855

German Federal Republic ■

Fluke (Deutschland) GmbH

Max-Hueber StraBe 8

8045 Ismaning, West Germany

Tel: (089) 96251, TLX: 522472

Rapifax: (089) 966718

Fluke (Deutschland) GmbH

MeineckestraBe 53

4000 Dusseldorf 30, West Germany

Tel: (0211) 450831, TLX: 8585576

Fluke (Deutschland) GmbH

Oberer Kirchhaldenweg 135

7000 Stuttgart 1, West Germany

Tel: (0711) 694091, TLX: 722518

Fluke (Deutschland) GmbH

Hubertusallee 46

1000 Berlin-33, West Germany

Tel: (030) 8911090

TLX: 0184978

Greece ■

Hellenic Scientific Representations Ltd.

11, Vrasside Street

Athens 615, Greece

Tel: (1) 711140, TLX: 219330

Hong Kong •

Schmidt & Co. (H.K.) Ltd.

28th F1, Wing on Centre

111 Connaught Road

Central Hong Kong

Tel: 5-455644

TLX: 74766 SCHMC HX

Hungary ■

Amtest Associates Ltd.

P.O. Box 55

Addlestone, Surrey KT15 1DU

United Kingdom

Tel: Weybridge (932) 52121

TLX: 928855

Iceland •

Kristjan O. Skagfjord Ltd.

P.O. Box 906

Reykjavik, Iceland

Tel: 24120, TLX: 2133

India •

Hinditron Services Pvt. Ltd.

69/A.L. Jagmohandas Marg

Bombay 400 006, India

Tel: 811316,

TLX: 953-112326 Hspl In

Hinditron Services Pvt. Ltd.

33/44-A 8th Main Road

Raj Mahl Vilas Extension

Bangalore 560 080, India

Tel: 33139

TLX: 0845741

Hinditron Services Pvt. Ltd.

Shantiniketan, Office No.6

6th Floor, 8 Camac Street

Calcutta 700 017, India

Tel: 434032, 447541

Hinditron Services Pvt. Ltd.

15 Community Centre, Panchshila Park

New Delhi 110 017, India

Tel: 619118

Hinditron Services Pvt. Ltd.

Srinath Complex, 5th Floor

1-1-58/1 to 1-1-58/11

Sarojini Devi Road

Secunderabad 500 003, India

Tel: 61705

Indonesia •

P.T. Dwi Tunggal Jaya Sakti

Sangga Buana Bldg., 1st Floor

Jl. Senen Raya 44, P.O. Box 4435

Jakarta, Indonesia

Tel: 367390-9, TLX: 46624

Iran ■

Irantronics Company Ltd.

20, Salm Road

Roosevelt Avenue, Tehran, Iran

Tel: 828294/831564

TLX: 212956

Iraq ■

Fluke (Holland) B.V.

P.O. Box 5053, Zevenheuvelenweg 53

5004 EB Tilburg, Netherlands

Tel: (013) 673973, TLX: 52237-

Ireland ■

Euro Electronics

32 Brews Hill

Naven County Meath, Ireland

Tel: (46) 23577, TLX: 3182

Israel ■

R.D.T. Electronics Engineering Ltd.

P.O. Box 75

46, Sokolov Street

Ramat Hasharon 47235, Israel

Tel: (3) 483212, TLX: 32143

Italy ■

Sistrel S.p.A.
Via Giuseppe Armellini No. 37
00143 Rome, Italy
Tel: (6) 5915551, TLX: 68356

Sistrel S.p.A.
Via Peilizza da Volpedo 59
20092 Cinisello besamo
Milan, Italy
Tel: (2) 6181893, TLX: 334643

Sistrel S.p.A.
Via Cintia Parco S. Paolo 35
80126 Naples, Italy
Tel: (81) 7679700

Japan ■

John Fluke Mfg. Co., Inc.
Japan Branch
(PC Board Testers only)
1 Higashikata-machi
Midori-ku
Yokohama 226, Japan
Tel: (045) 473-5425
TLX: 3823-666 FLKJPJ

Tokyo Electron Ltd.
38 FL Shinjuku Nomura Bldg.
1-26-2, Nishi-Shinjuku
Shinjuku-ku
Tokyo 160, Japan
Tel: 03-343-4411, TLX: 2322220

Kenya ■

ADCOM Ltd.
P.O. Box 30070
Nairobi, Kenya, East Africa
Tel: 331955, TLX: 22639

Korea ■

Electro-Science Korea Co.
C.P.O. Box 8446
Rm. 501, Boondo Bldg.
56-12 Jangchung-IKa
Jung-ku
Seoul, Korea
Tel: 261-7702, TLX: K25381

Kuwait ■

Tareq Company
P.O. Box Safat 20506
Kuwait, Arabian Gulf
Tel: 436100/436045
TLX: 2315

Lebanon and Jordan ■

Mabek (Electronics Division)
P.O. Box 11-3823
Beirut, Lebanon
Tel: 252631/348728
TLX: 22889

Libya ■

Fluke (Holland) B.V.
P.O. Box 5053, Zevenheuvelenweg 53
5004 EB Tilburg, Netherlands
Tel: (013) 673973, TLX: 52237

Malaysia ■

Rank O'Connor's (PTE) Limited
P.O. Box 91, Petaling Jaya
Selangor, West Malaysia
Tel: 566599
TLX: OCONOR MA37649

Rank O'Connor's (PTE) Limited
Lot No. 5 Taman Mesra
Mile 3, Jalan Penampang
Kota Kinabalu, East Malaysia
Tel: 55322, TLX: MA80286

Mexico ■

Christensen S.A. De C.V.
Instrumentos Electronicos de Medicion
Melchor Ocampo 150-8
Mexico 4 D.F., Mexico
Tel: (905) 535-2258
TLX: 1775612

Morocco ■

Mainvest
Residence Moulay Ismail, Bat. C.
12, Place des Alaouites
Rabat, Morocco
Tel: (7) 23990, TLX: 31036

Netherlands ■

Fluke (Nederland) B.V.
Zonneban 39
3606 CH Maarssen
P.O. Box 225
3600 AE Maarssen
Tel: (030) 436514, TLX: 47128

New Zealand ■

W & K McLean Ltd.
P.O. Box 18065, Glen Innes
Auckland, New Zealand
Tel: 587-037
TLX: N.Z. 7912763

W & K McLean Ltd.
P.O. Box 2421
Christchurch, New Zealand
Tel: 851-450

W & K McLean Ltd.
P.O. Box 496
Wellington, New Zealand
Tel: 851-450

Nigeria ■

Mofat Engineering Co., Ltd.
P.O. Box 6369
Lagos, Nigeria
Tel: 21353, Attn: MOFAT

Norway ■

Morgenstjerne & Co A/S
Konghellegate 3/5
P.O. Box 6688, Rodelokka
Oslo 5, Norway
Tel: (2) 356110, TLX: 11719

Pakistan ■

Pak International Operations
505 Muhammadi House
I.I. Chundrigar Road
P.O. Box 5323, Karachi, Pakistan
Tel: 221127, TLX: 24494

PDR Yemen ■

Fluke (Holland) B.V.
P.O. Box 5053, Zevenheuvelenweg 53
5004 EB Tilburg, Netherlands
Tel: (013) 673973, TLX: 52237

Peru ■

Importaciones Y Representaciones
Electronicas S.A.
Avda. Franklin D. Roosevelt 105
Lima 1, Peru
Tel: 288650, TLX: 37425663

Philippines ■

Spark Radio & Electric Supply
P.O. Box 610, Greenhills, San Juan
M. Manila, Philippines
Tel: 78-78-16
TLX: 27901 RLA PH

Poland ■

Amtest Associates Ltd.
P.O. Box 55
Addlestone, Surrey KT15 1DU
United Kingdom
Tel: Weybridge (932) 52121
TLX: 928855

Portugal ■

Decada-Equipamentos
de Electronica, Lda.
P.O. Box 1128, 1003
Lisbon Codex, Portugal
Tel: (1) 574984, TLX: 18469

Qatar ■

Technology Organisation
P.O. Box 5549, Doha, Qatar
Tel: 321431, TLX: 4581

Romania ■

Amtest Associates Ltd.
P.O. Box 55
Addlestone, Surrey KT15 1DU
United Kingdom
Tel: Weybridge (932) 52121
TLX: 928855

Saudi Arabia ■

Electronic Equipment Marketing Co. Ltd.
P.O. Box 3750
Riyadh, Saudi Arabia
Tel: 4032761, TLX: 201120

Singapore ■

Rank O'Connor's (PTE) Limited
98 Pasir Panjang Road
Singapore 0511
Republic of Singapore
Tel: 637944
TLX: OCONSIN RS21023

Somalia ■

Fluke (Holland) B.V.
P.O. Box 5053, Zevenheuvelenweg 53
5004 EB Tilburg, Netherlands
Tel: (013) 673973, TLX: 52237

South Africa ■

Fluke S.A. (Pty) Ltd.
P.O. Box 39797, Bramley 2018
Republic of South Africa
Tel: (011) 786-3170, TLX: 424328

Spain ■

Hispano Electronca S.A.
Piliqono Industrial Urtinas
Apartado de Correos 48
Alcorcon (Madrid), Spain
Tel: (1) 6194108
TLX: 22404/42634

Sweden ■

Teinstrument AB
P.O. Box 4490
162 04 Vallingby, Sweden
Tel: (8) 380370, TLX: 11347

Switzerland ■

Traco Electronic Company Ltd.
Jenatschstrasse 1
8002 Zurich, Switzerland
Tel: (1) 2010711, TLX: 54318

Syria ■

Mabek (Electronics Division)
P.O. Box 4238
Damascus, Syria

Taiwan ■

CCT Associates, Inc.
P.O. Box 32-79
Taipei, Taiwan, Republic of China
Tel: (02) 391-6894,
TLX: 24263 Longgulf

Thailand ■

Dynamic Supply Engineering R.O.P.
12 SOI, Pasana 1, Ekami Sukhumvit 63
Bangkok-11, Thailand
Tel: 3925313
TLX: TH 82938 MONTIEN TH

Tunisia ■

Selep S.A.R.L.
6, Rue de Sparte
Tunis - 1000 RP, Tunisia
Tel: (1) 248093, TLX: 13030

Turkey ■

Erkman Elektronik Aletler
Ticaret Anonim Sirketi
Necatibey Cad 92/3
Karakoy, Istanbul, Turkey
Tel: (1) 5461
TLX: 23353

United Arab Emirates & Oman ■

Haris A1-Afag Ltd.
P.O. Box 545
Sharjah, United Arab Emirates
Tel: 35912/359121/359122/359123
TLX: 23966

United Kingdom ■

Fluke (G B) Ltd.
Colonial Way
Watford, Herts, WD2 4TT
United Kingdom
Tel: (0923) 40511, TLX: 934583
Rapifax: (0923) 25067

Uruguay ■

Coasin Uruguaya S.R.L.
Cuareim 2196
Casilla de Correos 1400
Correo Central
Montevideo, Uruguay
Tel: 29-31-95, TLX: 37425663

U.S.S.R. ■

Amtest Associates Ltd.
P.O. Box 55
Addlestone, Surrey KT15 1DU
United Kingdom
Tel: Weybridge (932) 52121
TLX: 928855

Venezuela ■

Coasin, C.A.
Calle 9 Con Calle 4, Edif. Edinurbi
Piso 3, La Urbina
Apartado De Correos NR-70.136 Los Rios
Caracas 1070A, Venezuela
Tel: 38-78-42, TLX: 2102

Yemen ■

Fluke (Holland) B.V.
P.O. Box 5053, Zevenheuvelenweg 53
5004 EB Tilburg, Netherlands
Tel: (013) 673973, TLX: 52237

Yugoslavia ■

Amtest Associates Ltd.
P.O. Box 55
Addlestone, Surrey KT 15 1DU
United Kingdom
Tel: Weybridge (932) 52121
TLX: 928855

■ Supplied and Supported by —

Fluke (Holland) B.V.
P.O. Box 5053, Zevenheuvelenweg 53
5004 EB Tilburg, Netherlands
Tel: (013) 673973, TLX: 52237

■ Supplied and Supported by —

Fluke International Corporation
P.O. Box C9090
Everett, WA 98206
Tel: (206) 356-6300
TLX: 152662 JOHNFLUKE MTLT

■ Latin America also supported by —

Sr. Benewaldo Padovani
c/o AROTEC S.A.
Industria e Comercio
Av. Pacaembu 811
01234 Sao Paulo S.P., Brazil
Tel: (011) 826-2266
TLX: 1122207 AROT BR

Section 8

Schematic Diagrams

TABLE OF CONTENTS

FIGURE	TITLE	PAGE
8-1	A1 Main PCB Assembly	8-2
8-2	A2 Low Ohms PCB Assembly	8-6
8-3	Custom IC (U3) Block Diagram	8-7

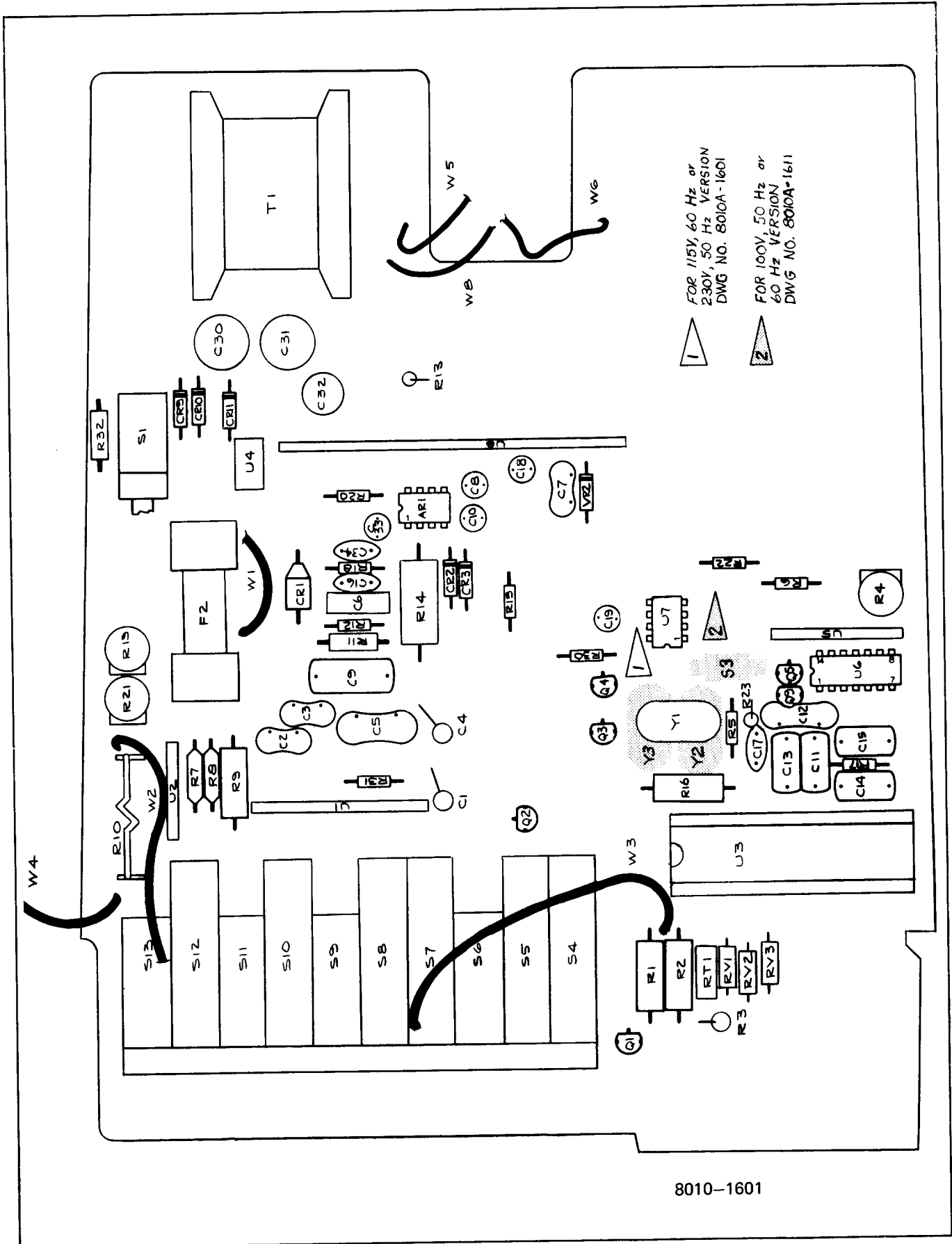

8010-1601

Figure 8-1. A1 Main PCB Assembly

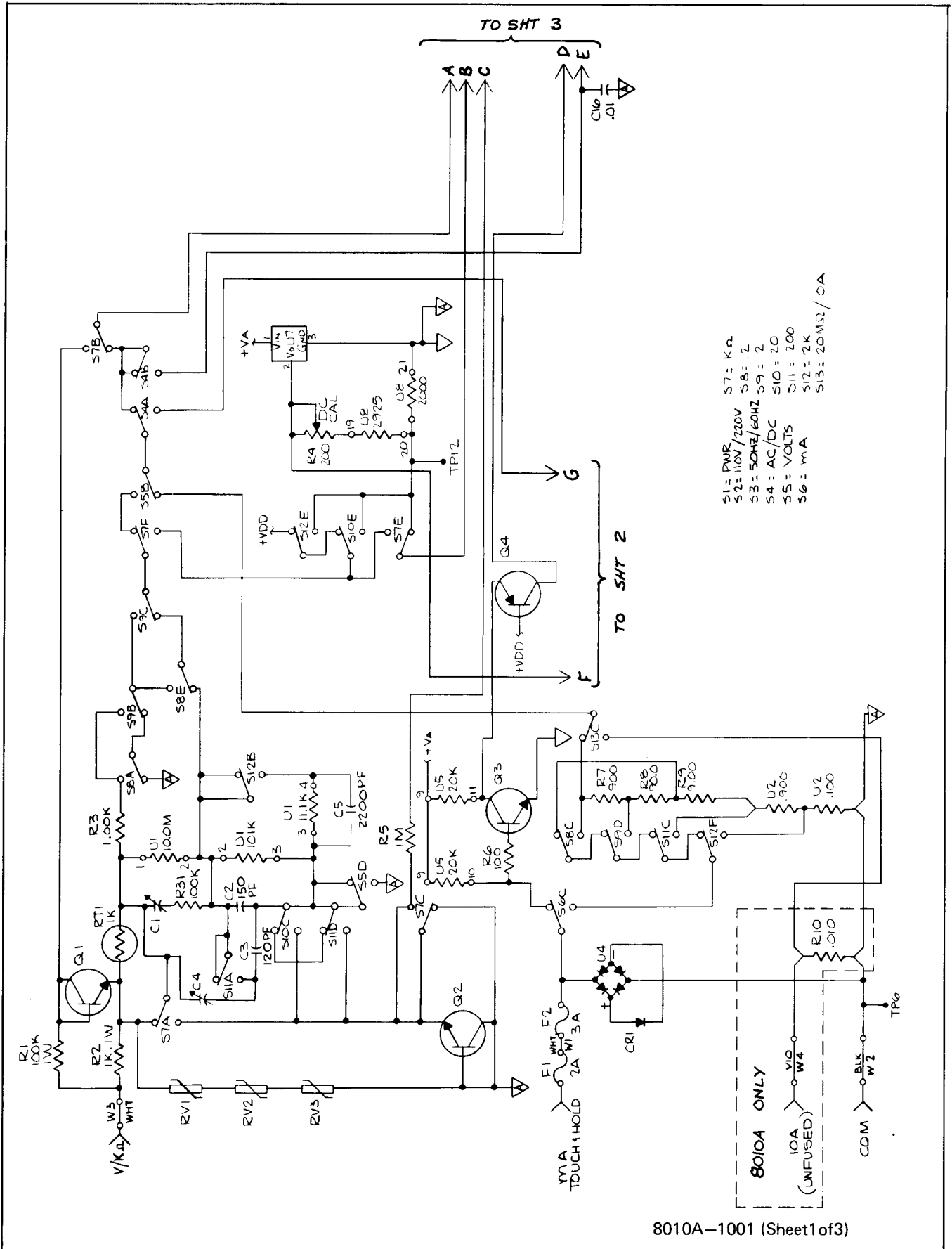

- S1 = PWR
- S2 = 110V/220V
- S3 = 50Hz/60Hz
- S4 = AC/DC
- S5 = VOLTS
- S6 = mA
- S7 = KΩ
- S8 = Ω
- S9 = 2
- S10 = 20
- S11 = 200
- S12 = 2K
- S13 = 20MΩ/ΩA

Figure 8-1. A1 Main PCB Assembly (cont)

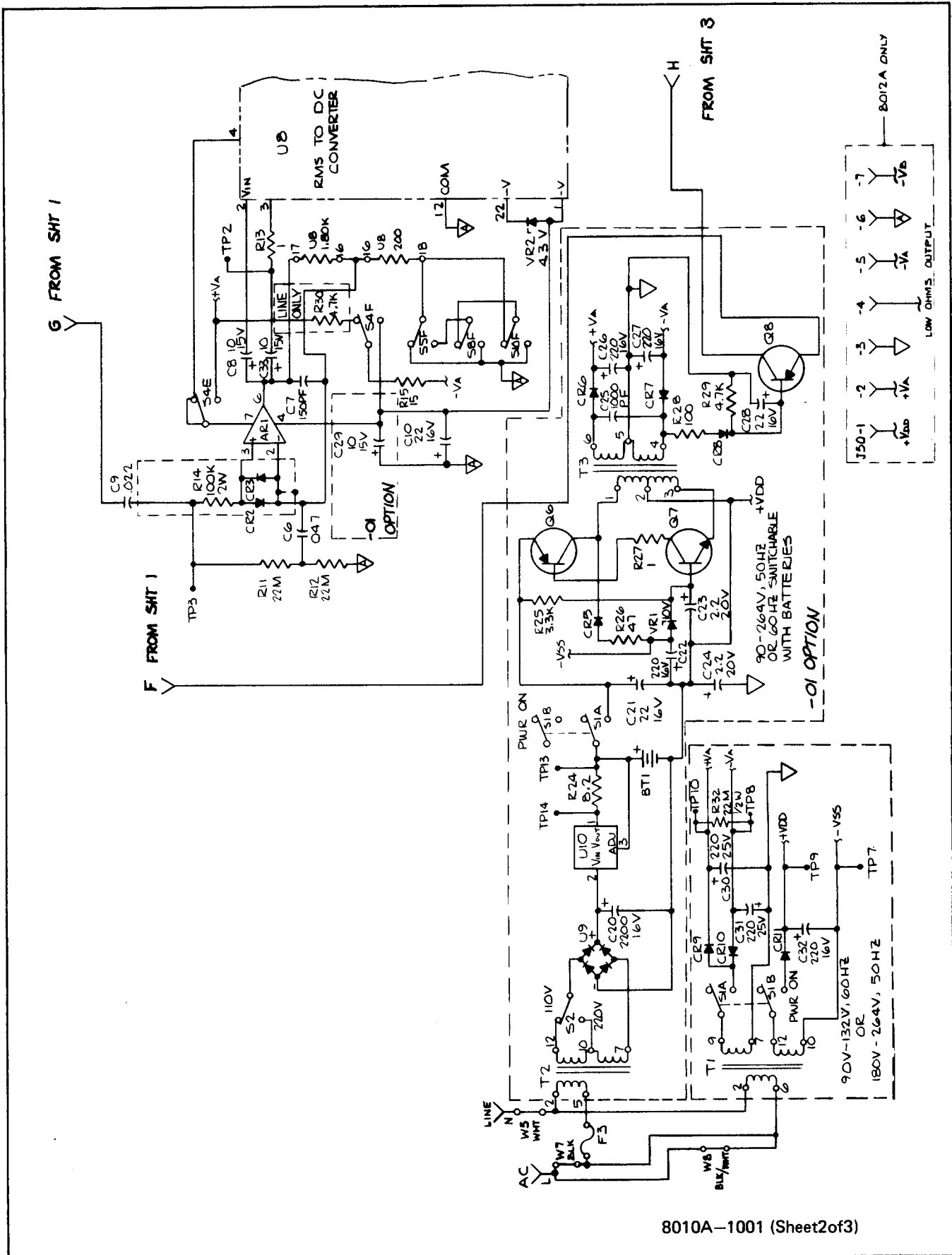

8010A-1001 (Sheet2of3)

Figure 8-1. A1 Main PCB Assembly (cont)

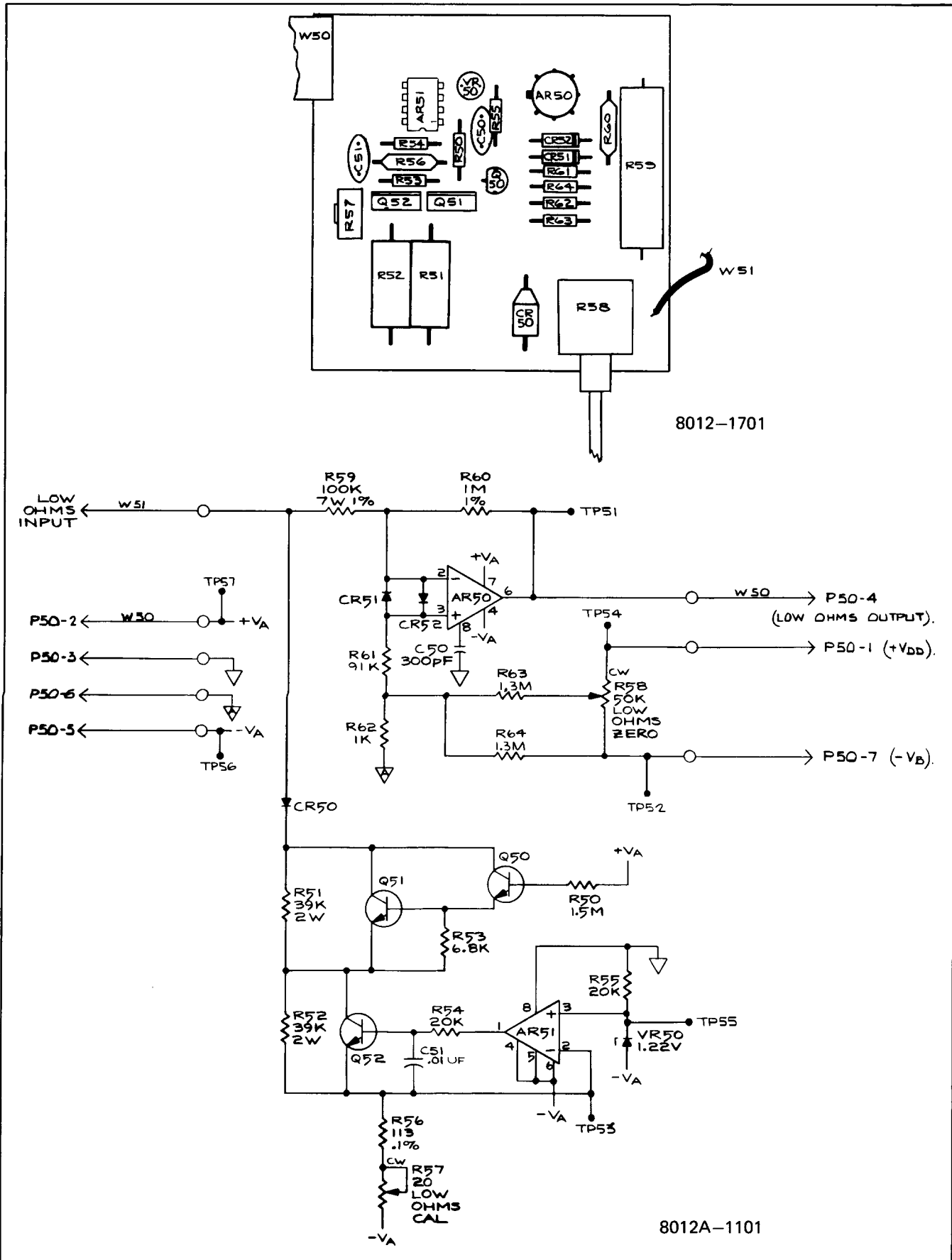

Figure 8-2. A2 Low Ohms PCB Assembly

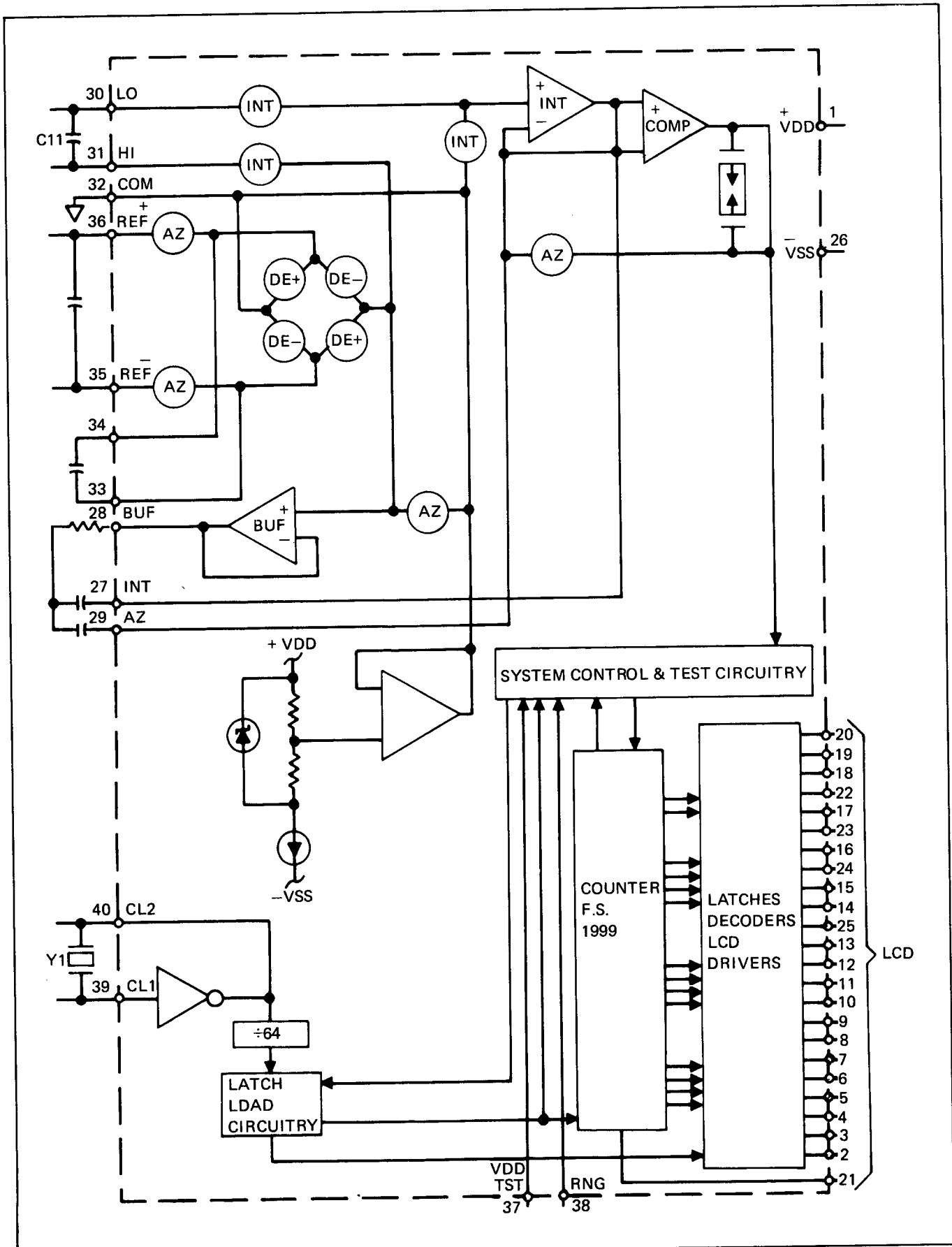

Figure 8-3. Custom IC(U3) Block Diagram

WARRANTY

Notwithstanding any provision of any agreement the following warranty is exclusive:

The JOHN FLUKE MFG. CO., INC., warrants each instrument it manufactures to be free from defects in material and workmanship under normal use and service for the period of 1-year from date of purchase. This warranty extends only to the original purchaser. This warranty shall not apply to fuses, disposable batteries (rechargeable type batteries are warranted for 90-days), or any product or parts which have been subject to misuse, neglect, accident, or abnormal conditions of operations.

In the event of failure of a product covered by this warranty, John Fluke Mfg. Co., Inc., will repair and calibrate an instrument returned to an authorized Service Facility within 1 year of the original purchase; provided the warrantor's examination discloses to its satisfaction that the product was defective. The warrantor may, at its option, replace the product in lieu of repair. With regard to any instrument returned within 1 year of the original purchase, said repairs or replacement will be made without charge. If the failure has been caused by misuse, neglect, accident, or abnormal conditions of operations, repairs will be billed at a nominal cost. In such case, an estimate will be submitted before work is started, if requested.

THE FOREGOING WARRANTY IS IN LIEU OF ALL OTHER WARRANTIES, EXPRESS OR IMPLIED, INCLUDING BUT NOT LIMITED TO ANY IMPLIED WARRANTY OF MERCHANTABILITY, FITNESS, OR ADEQUACY FOR ANY PARTICULAR PURPOSE OR USE. JOHN FLUKE MFG. CO., INC., SHALL NOT BE LIABLE FOR ANY SPECIAL, INCIDENTAL, OR CONSEQUENTIAL DAMAGES, WHETHER IN CONTRACT, TORT, OR OTHERWISE.

If any failure occurs, the following steps should be taken:

1. Notify the JOHN FLUKE MFG. CO., INC., or nearest Service facility, giving full details of the difficulty, and include the model number, type number, and serial number. On receipt of this information, service data, or shipping instructions will be forwarded to you.
2. On receipt of the shipping instructions, forward the instrument, transportation prepaid. Repairs will be made at the Service Facility and the instrument returned, transportation prepaid.

SHIPPING TO MANUFACTURER FOR REPAIR OR ADJUSTMENT

All shipments of JOHN FLUKE MFG. CO., INC., instruments should be made via United Parcel Service or "Best Way" prepaid. The instrument should be shipped in the original packing carton; or if it is not available, use any suitable container that is rigid and of adequate size. If a substitute container is used, the instrument should be wrapped in paper and surrounded with at least four inches of excelsior or similar shock-absorbing material.

CLAIM FOR DAMAGE IN SHIPMENT TO ORIGINAL PURCHASER

The instrument should be thoroughly inspected immediately upon original delivery to purchaser. All material in the container should be checked against the enclosed packing list. The manufacturer will not be responsible for shortages against the packing sheet unless notified immediately. If the instrument is damaged in any way, a claim should be filed with the carrier immediately. (To obtain a quotation to repair shipment damage, contact the nearest Fluke Technical Center.) Final claim and negotiations with the carrier must be completed by the customer.

The JOHN FLUKE MFG. CO., INC., will be happy to answer all applications or use questions, which will enhance your use of this instrument. Please address your requests or correspondence to: JOHN FLUKE MFG. CO., INC., P.O. BOX C9090, EVERETT, WASHINGTON 98206, ATTN: Sales Dept. For European Customers: Fluke (Holland) B.V., P.O. Box 5053, 5004 EB, Tilburg, The Netherlands.

*For European customers, Air Freight prepaid.

John Fluke Mfg. Co., Inc., P.O. Box C9090, Everett, Washington 98206

P/N 491944
August 1978
Litho in U.S.A.

John Fluke Mfg. Co., Inc. / PO Box 43210 / Mountlake Terrace, WA 98043